

Wheel Loaders

L 550 - L 586

Xpower[®]

Xpower[®]

Generation

6

Tipping load

27,560 – 47,620 lb

Engine

Tier 4f



LIEBHERR



reddot award 2016
winner

Performance

Power for
Increased Productivity

Economy

Minimum Costs at
High Handling Capacity

L 550 XPower®

Tipping load, articulated

27,560 lb

Bucket capacity

4.5 yd³

Operating weight

40,895 lb

Engine output

163 kW/219 HP

L 556 XPower®

Tipping load, articulated

30,315 lb

Bucket capacity

4.8 yd³

Operating weight

43,210 lb

Engine output

183 kW/245 HP

L 566 XPower®

Tipping load, articulated

35,055 lb

Bucket capacity

5.5 yd³

Operating weight

52,690 lb

Engine output

203 kW/272 HP

L 580 XPower®

Tipping load, articulated

42,330 lb

Bucket capacity

6.8 yd³

Operating weight

60,955 lb

Engine output

233 kW/312 HP

L 586 XPower®

Tipping load, articulated

47,620 lb

Bucket capacity

7.8 yd³

Operating weight

71,870 lb

Engine output

263 kW/353 HP



Reliability

Ruggedness and Quality
for Durable Machines

Comfort

Maximum Operator Comfort
for More Productivity

Maintainability

Time and Cost Savings
Through Simple Maintenance



Performance



Power for Increased Productivity

The innovative Liebherr-XPower® driveline considerably increases working efficiency. Quick working cycles, high tipping loads and high machine availability lead to increased handling capacity.

Powerful and Efficient Drive Concept

Highest Level of Performance

The Liebherr-XPower® driveline brings together the hydrostatic and mechanical drive. The interaction between these two different drives is continuously adjusted automatically to the given application. As a result, XPower® offers the optimal level of efficiency during material loading and transport, as well as providing maximum acceleration and performance along all loading cycles – including long routes. All components are also ideally adapted to each other. XPower® stands for maximum efficiency.

Continuously Variable Transmission

The Liebherr-XPower® driveline allows continuous adjustment of acceleration in all speed ranges, without noticeable gear shifting or interruption in tractive force. Powerful working and high driving comfort increases productivity.

High Handling Capacity

Unnecessary counterweight can be avoided through the unique component mounting position at the rear of the machine. Ideal weight distribution results in high tipping loads and greater handling capacity per hour of operation.

The Liebherr-XPower® driveline accelerates quickly, allowing high travel speeds. Time savings can be made on flat terrain, as well as on inclines. As a result, there are considerable gains in productivity.

Flexibility and Versatility

Lift Arm Variants Optimized for the Application

The standard Z-bar linkage provides a large torque in the lower region of the lift arm. The ideal prerequisite for conventional wheel loader applications – simple, quick filling of the bucket leads to high handling capacity.

An alternative is available in the form of the industrial lift arm for L 550 – L 580 wheel loaders at no extra charge. The industrial lift arm features a parallel guide arrangement and especially high torque in the upper lifting range. The best solution for industrial use as it allows large attachments to be fitted for transporting heavy loads.

Optimal Bucket Filling

The new robust bucket design from Liebherr allows the bucket to be filled quickly and efficiently. Fully filled attachments increase productivity. The bucket's good penetration and simple filling mechanism result in lower fuel consumption.

Wide Range of Applications

The wide range of attachments means the right tool is always to hand. As a result, a multitude of uses can easily be covered. This increases utilization of the machine and raises productivity. Liebherr wheel loaders can manoeuvre quickly and efficiently thanks to their compact design – the best choice for high handling capacity.

Liebherr-XPower® Driveline

L 550 – L 586

- Trend-setting driveline for powerful uses
- Optimum weight distribution due to its unique component mounting position
- Ideal visibility due to its compact design

Conventional Travel Gear

- Center of gravity in the middle of the machine
- Additional ballast is needed to increase the tipping load and improve stability
- This leads to bad visibility

An All-Purpose Loader

The option to choose between industrial lift arm and Z-bar linkage means the right machine is always available for the use specifically required by the customer.

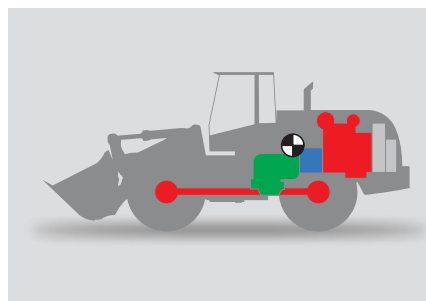
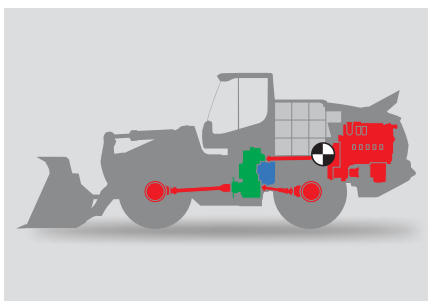

Economy



Minimum Costs at High Handling Capacity

Liebherr wheel loaders make a reliable contribution to commercial success. The fuel-efficient drive concept reduces operating costs and environmental impact at maximum handling capacity.

Low Operating Costs

Lower Fuel Consumption

The Liebherr-XPower® driveline with Liebherr-Power-Efficiency (LPE) achieves a reduction in fuel consumption of up to 30% when compared to conventional travel gears. At highest efficiency this reduces operating costs and increases profitability.

Practically No Brake Wear

The Liebherr-XPower® driveline brakes automatically. The service brake only acts as a support and is therefore subject to hardly any wear.

Minimal Tire Wear

Its continuous traction control, combined with automatic self-locking differential, prevents wheelspin. Productivity is increased and tire wear reduced by up to 25%.

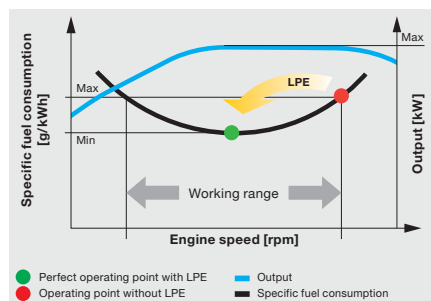

Low Fuel Consumption Thanks to Intelligent Machine Control

- Liebherr-Power-Efficiency (LPE) optimizes the interaction between diesel engine, gearbox and working hydraulics for maximum efficiency
- LPE – maximum performance from every drop of fuel

Save Costs and Protect the Environment

Innovative Exhaust Gas Treatment

The Liebherr-SCR technology is an efficient system for the gas treatment of exhaust gases. Consumables around the engine, such as diesel particle filters, are not required. Regeneration is no longer necessary and maintenance is reduced. Higher productivity provide fuel savings and a reduction in operating costs.

Economical Use of Resources

The lower fuel consumption and efficient exhaust gas treatment cut emissions. This actively saves resources. While actively protecting the environment, Liebherr wheel loaders reduce operating costs.



Reduced Brake Wear

Hardly any brake wear due to hydraulic-mechanical braking action of the driveline.

Reduced Tire Wear

Continuous traction control prevents the wheels from spinning.

LiDAT

Efficient Management

LiDAT, Liebherr's own data transmission and positioning system, facilitates efficient management, monitoring and control of the entire fleet park in terms of machinery data recording, data analysis, fleet park management and service. All of the important machinery data can be viewed at any time in a web browser. LiDAT offers you comprehensive work deployment documentation, greater availability thanks to shorter downtimes, faster support from the manufacturer, quicker detection of strain/overload and subsequently a longer service life of the machine as well as greater planning efficiency in your company. This service includes 1 year of use free of charge as standard for the L 550 XPower® – L 586 XPower® wheel loaders.



Always Be Informed with LiDAT

- Evaluation of machine usage and fuel consumption for economic machine management
- LiDAT comes as standard incl. 1 year free-of-charge use

Reliability



Ruggedness and Quality for Durable Machines

Liebherr wheel loaders provide maximum performance even under the toughest of operating conditions. Specially-developed components, sophisticated technology and high quality offer a high level of reliability and availability.

OEM Quality Components

Durable and Powerful

Liebherr has many decades of experience in the development, construction and production of components. Ideally adapted to each other, they guarantee a high degree of performance and reliability. Liebherr also develops and produces all steel components. These rugged components ensure the long life of the wheel loaders.

Strenuous endurance tests prove to the strength and quality of the components in use. Even under the toughest of usage conditions, Liebherr wheel loaders satisfy Liebherr's stringent quality standards. This ensures reliable use throughout the entire life time of the machine. Consistently powerful machines increase productivity.



Powerful Liebherr's Own Components

- Ideal interaction of components to each other for maximum performance
- Maximum endurance even under the toughest operating conditions
- Rugged, durable machines for reliable operations

High Safe and Versatile Usage

Wear-Free Drive Concept

The components of the Liebherr XPower® driveline are extremely robust and low-wear. The variable distribution of forces between the hydrostatic and mechanical drive also leads to reduced loads on the drive path. XPower® ensures a long life time of the machine and reliability in use.

Continuous Use

Thanks to Liebherr's unique SCR technology, fewer components – such as diesel particle filters or exhaust gas recirculation – are not needed at the engine. This minimizes the risk of failure and reduces maintenance expense. This sophisticated technology ensures efficient, continuous work.

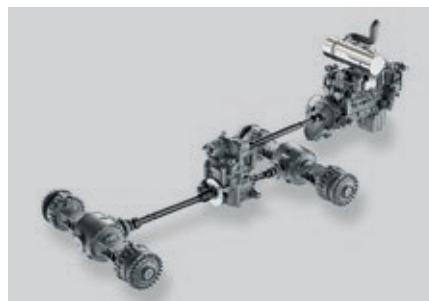

High Machine Availability

- Reduced load on the driveline through the subdivision of forces
- High, safe and versatile usage thanks to robust, low-wear components
- Fewer components around the engine mean reduced risk of failure

Reliable Cooling System

Optimal Cooling Performance

The cooling system is fitted directly behind the operator's cab and is thus able to take in air which is free of dust. In especially dusty applications, the reversible fan drive is a standard feature, a particle protection for the radiator and a large mesh radiator are available as options to protect the cooling system from contaminants getting in. This guarantees continuous cooling output while simultaneously reducing cleaning expenses. Minimal cleaning expenses mean more efficient, more cost-effective working.

Controlled Cooling

The cooling fan is driven independently from the Liebherr diesel engine and produces exactly the cooling air output which is actually required. Heat sensors ensure reliable control.



Intelligent Cooling System

- Cooling position on the cleanest position of the wheel loader
- High machine availability thanks to lower radiator contamination
- Controlled cooling through thermostatic control for reliable operations

Comfort



Maximum Operator Comfort for More Productivity

The cab design is optimally adapted to the operator's day-to-day requirements. The roomy and ergonomic operator's cab offers perfect conditions for comfortable and productive work.

Clearly Arranged Cab

Productive and Safe Working

The modern, ergonomic cab design allows the operator to work with high concentration without fatigue – this increases safety and productivity. The displays, controls and operator's seat are carefully coordinated to form an ergonomic unit. The optional laterally-sprung operator's seat offers high seating comfort and relaxed working.

Perfect Visibility

The generous glass surfaces of the cab offer exceptional all-round visibility of the attachment and working area. The design of the engine hood which has been optimized for viewing provides ideal viewing towards the rear as well as monitoring behind the machine from the Liebherr display. This ensures maximum safety for people, the machine and the load, while increasing productivity at the same time.

Well-Being Guaranteed

Optimum storage areas and stowage spaces and optional cool-box increase operator well-being. With air conditioning as standard, the improved cooling output ensures a pleasant working atmosphere. This gives the operator maximum comfort and high productivity.

The optional Liebherr key with remote control incl. Coming Home/Leaving Home function opens the operator's door automatically and turns on the lights – for safe and comfortable start-up of the machine.

Exceptional All-Round Visibility

- Unobstructed visibility in all directions through optimal cab and engine hood design
- Generous glass surfaces
- More safety and productivity thanks to exceptional visibility



Simple and Intuitive Operation

Joystick Steering (optional)

The optional joystick steering integrated in the operator's seat is a new, innovative and improved steering system. This means that all working and driving functions of the machine can be controlled, precisely and with a high degree of sensitivity. The intuitive operation is similar to that of a steering wheel, and the joystick's orientation corresponds to the desired wheel loader articulation angle. In addition, the forces acting on the steering are transmitted to the joystick. This makes precise and safe operation possible at any speed.

The operator's cab is also optionally available without steering wheel and column with joystick steering only. Moving your hands between the steering unit and the control unit is not necessary, which increases safety and comfort.

Touchscreen Display

The height-adjustable 9" touchscreen display, which comes as standard, allows all operating-relevant machine data to be viewed and configured quickly. Visual and acoustic warning devices ensure high operational reliability.

LIKUFIX for Industrial Lift Arm (optional)

LIKUFIX is a hydraulic quick coupler with an integral automated hydraulic coupling system, which is available as an option. A wide range of hydraulic and mechanical attachments can be changed fully automatically, safely and without any oil leaks direct from the cab in a matter of seconds by pressing a button. LIKUFIX contributes to higher utilization of the wheel loader, thus increasing operational efficiency.

Joystick Steering (optional)

- Ergonomic and comfortable operation
- Speed-dependent force feedback for precise and safe steering behavior
- Simple handling through intuitive operation



Intuitive Controls

- Quick recoding of operation-relevant machine data
- Ease of controls increases working efficiency
- Liebherr reverse camera available as standard – built into the touchscreen display



Maintainability



Time and Cost Savings Through Simple Maintenance

The most important points for daily maintenance can be seen at a glance in the access area of Liebherr-XPow^{er}® wheel loaders. Quick and safe checks save time and money.

Exceptional Service Accessibility

Efficient and Simple Maintenance

Thanks to the unique mounting position of the components, Liebherr wheel loaders offer exceptional accessibility for maintenance. The positioning of the cooling package directly behind the operator's cab contributes to a reduction in maintenance and cleaning expenses by reducing contamination. This saves time and money.

Safe and Free Service Access

All points requiring day-to-day maintenance can be reached comfortably, safely and cleanly. Anti-slip steps and sturdy handrails provide a high degree of safety.

Short Service Times for More Productivity

The engine hood, which opens up electrically towards the rear, ensures safe, free access to the entire engine compartment. The service points are easy to see and reach. All maintenance work can be carried out comfortably and safely from a level base in the engine hood. This ensures time-saving maintenance and increases productivity.

Improved access to the windscreen and cab filter box is provided by the access on the right hand side of the machine. Sturdy hand rails and a fold-out ladder provide a high level of safety during cleaning and maintenance.

Strong Service Partner

Safe Partnership with Strong Service

When buying a Liebherr wheel loader the customer not only looks to a long-lived high-end product but also a reliable longterm partnership. A service network combined with a highly-modern central warehouse is available for optimum service and quick replacement part provision. This guarantees short routes and rapid support in the event of service. Round-the-clock if required.

Competent Liebherr Service Offers Maximum Reliability

Comprehensive know-how ensures a first-class execution of all service and maintenance work. This contributes decisively to the availability and profitability of your machine. Employees at Liebherr service partners are trained on an ongoing basis. They have extensive knowledge of quick and safe service performance. They can turn to the expertise of manufacturing plants at any time.

Low Maintenance

- Less contamination of the radiator thanks to its clever position behind the operator's cab
- Quick and safe control saves time and money

Optimum Service Accessibility

- The entire engine compartment is accessible via just one enclosure
- The most important fill levels can be seen in the loading area
- Short downtimes means more efficiency

Perfect Service for Optimum Machine Availability

- Quick and effective support thanks to an extensive service network
- Replacement parts service with 24-hour delivery
- Quick and reliable service carried out by qualified service specialists



Wheel Loaders L 550 XPower® - L 586 XPower® Overview

Sturdy Attachment

- + Quick working cycles
- + Durable lift arm
- + Flexible in use
- + Efficient and cost-optimized use by specially adapted lift arm variants

- ✓ High-quality hydraulic components
- ✓ Strong steel construction
- ✓ Wide range of attachments
- ✓ Industrial lift arm and Z-bar linkage optional

Powerful and Efficient Liebherr-XPower® Driveline

- + Fuel savings of up to 30 %
- + High performance
- + High safe and versatile usage
- + Maximum productivity by high tipping load
- + Tire wear reduced by up to 25 %
- + Practically no brake wear
- + Maximum stability and safety on all terrains

- ✓ Drive components optimally suited to each other by LPE
- ✓ Powerful power split driveline
- ✓ Rugged and durable driveline
- ✓ Ideal weight distribution by intelligent arrangement of drive components
- ✓ Continuous tractive force prevents wheelspin
- ✓ Self-locking hydraulic-mechanical brake system





Comfortable Operator's Cab

- + Increased performance and productivity
 - + Focused operator work is supported
 - + Easy and safe operation
 - + Excellent all-round visibility
-
- ✓ New, modern and ergonomic cab design
 - ✓ Control of working and travel functions with Liebherr control lever mounted into the operator's seat
 - ✓ Generous glass surfaces

Intelligent Cooling System

- + Constant and reliable cooling
 - + Increased service life of components
 - + High machine availability through minimal cleaning expenses
-
- ✓ Controlled cooling
 - ✓ Heat sensors ensure reliable control
 - ✓ The radiator is installed directly behind the operator's cab – the cleanest position of the wheel loader

Optimum Service Accessibility

- + Time savings in daily maintenance
 - + Short service times for more productivity
-
- ✓ Rapid control of the most important maintenance points in the access area
 - ✓ Safe, simple and quick access to all points important for operations

Technical Data



Motor

	L 550	L 556
Diesel engine	D934 A7	D944 A7
Design	Water-cooled in-line engine with charge-air cooling	
Cylinder inline	4	4
Fuel injection process	Electronic Common Rail high-pressure injection	
Output		
to ISO 9249/ ECE-R.24	kW/HP 160/215 at RPM 1,800	180/241 1,800
Rated output to ISO 14396/ ECE-R.120	kW/HP 163/219 at RPM 1,800	183/245 1,800
Nominal speed	at RPM 1,800	
Max. torque to ISO 14396/ ECE-R.120	lb ft 920 at RPM 1,100	1,035 1,150
Displacement	in ³ 428	
Bore/Stroke	in 4.8"/5.91"	
Tier 4f		
Harmful emissions values	In accordance with EPA 40 CFR part 1039 and CARB 13 CCR section 2423	
Emission control	Liebherr-SCR technology	
Fuel tank	gal 74	74
DEF tank	gal 17.8	17.8
Air cleaner system	Dry type filter with main and safety element, pre-cleaner, service indicator on the Liebherr display	
Electrical system		
Operating voltage	V 24	24
Capacity	Ah 2 x 140	2 x 140
Alternator	V/A 28/140	28/140
Starter	V/HP 24/10.5	24/10.5

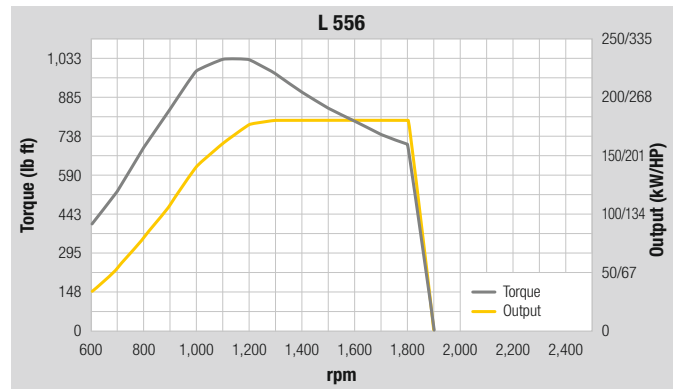
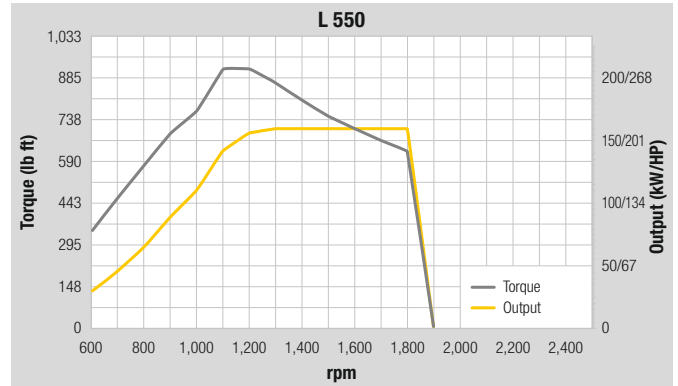

Driveline

Continuous power split XPower® driveline	
Design	Continuous, fully-automatic XPower® driveline. No traction interruptions across the entire speed range. Hydrostatic power split with two axial piston units. Identical driving performance – forwards and in reverse
Filtration	Filter system for driveline, depend on working hydraulics
Control	Driveline is controlled from travel pedal for tractive force and speed setting with integrated inch function. The Liebherr control switch is used to control forward and reverse travel
Travel speed range	0 – 24.9 mph forward and reverse, fully-automatic Speed restriction available upon request. Speeds quoted apply with the standard tires as indicated on loader model.



Axles

	L 550	L 556
Four-wheel drive		
Front axle	Fixed	
Rear axle	Center pivot, with 13° oscillating angle to each side	
Height of obstacles which can be driven over	ft in 1'6"	1'5"
	with all four wheels remaining in contact with the ground	
Differentials	Automatic limited-slip differentials	
Reduction gear	Planetary final drive in wheel hubs	
Track width	6'7" with all types of tires	



Brakes

Wear-free service brake	Self-locking of the XPower® driveline (acting on all four wheels) and additional pump-accumulator brake system with wet multi-disc brakes (two separate brake circuits)
Parking brake	Electro-hydraulically actuated spring-loaded disc brake system on the transmission

The braking system meets the requirements of the ISO 3450.



Steering

Design	“Load-sensing” swash plate type variable flow pump with pressure cut-off and flow control. Central pivot with two double-acting, damped steering cylinders
Angle of articulation	40° to each side
Emergency steering	Electro-hydraulic emergency steering system



Attachment Hydraulics

	L 550	L 556
Design	“Load-sensing” swash plate type variable flow pump with output and flow control, and pressure cut-off in the control block	
Cooling	Hydraulic oil cooling using thermostatically controlled fan and oil cooler	
Filtration	Return line filter in the hydraulic reservoir	
Control	Liebherr control lever, electro-hydraulically operated	
Lifting function	Lifting, neutral, lowering Automatic lift arm position and lowering by Liebherr control lever Float position controlled by Liebherr control lever	
Tilt function	Tilt back, neutral, dump Automatic bucket return for tilting back and dumping controlled by Liebherr control lever	
Max. flow	gpm 62	77
Max. pressure		
Z-bar linkage	psi 5,076	5,076
Industrial lift arm	psi 5,511	5,511



Attachment

	L 550	L 556		
Geometry variants				
Optional	Powerful Z-bar linkage with tilt cylinder and cast steel cross-tube Industrial lift arm with tilt cylinder, hydraulic quick coupler standard			
Bearings	Sealed			
Cycle time at nominal load	ZK	IND	ZK	IND
Lifting	s 5.4	5.4	5.4	5.4
Dumping	s 1.0	2.2	1.0	2.2
Lowering (empty)	s 2.9	2.9	2.9	2.9



Operator's Cab

Design	Hydraulically mounted, noise-proof cab ROPS roll over protection per EN ISO 3471 / EN 474-1 FOPS falling objects protection per EN ISO 3449 / EN 474-1, Cat. II Operator's door with sliding side window, sliding side window on right, front windscreen made of compound safety glass, side panels with single-pane safety glass ESG, heated rear window ESG, all windows are tinted. 3 way continuous adjustable steering column
Liebherr operator's seat	6 way adjustable, vibration-damped operator's seat “Comfort” with seat, depth and incline adjustment standard (air-cushioned with seat heating adjustable to operator's weight), Liebherr control lever mounted into the operator's seat standard
Cab heating and ventilation	4-zone air conditioning with new improved cooling output standard, electrically heated rear window, all filters are easy to access and replaceable



Sound Level

	L 550	L 556
Sound pressure level to ISO 6396		
L _{PA} (inside cab)	dB(A) 68	68
Sound power level to 2000/14/EC		
L _{WA} (surround noise)	dB(A) 104	104



Capacities

	L 550	L 556
Engine oil (inclusive filter change)	gal 6.9	6.9
Pump distribution gearbox	gal 0.3	0.3
XPower® gearbox	gal 14	14
Coolant	gal 17.7	17.7
Front axle	gal 9.2	11.1
Rear axle	gal 9.2	9.2
Hydraulic tank	gal 27.7	27.7
Hydraulic system, total	gal 46.2	47.6
Air conditioning system R134a	lb 2.8	2.8

Dimensions

Z-bar Linkage

L 550 – L 556

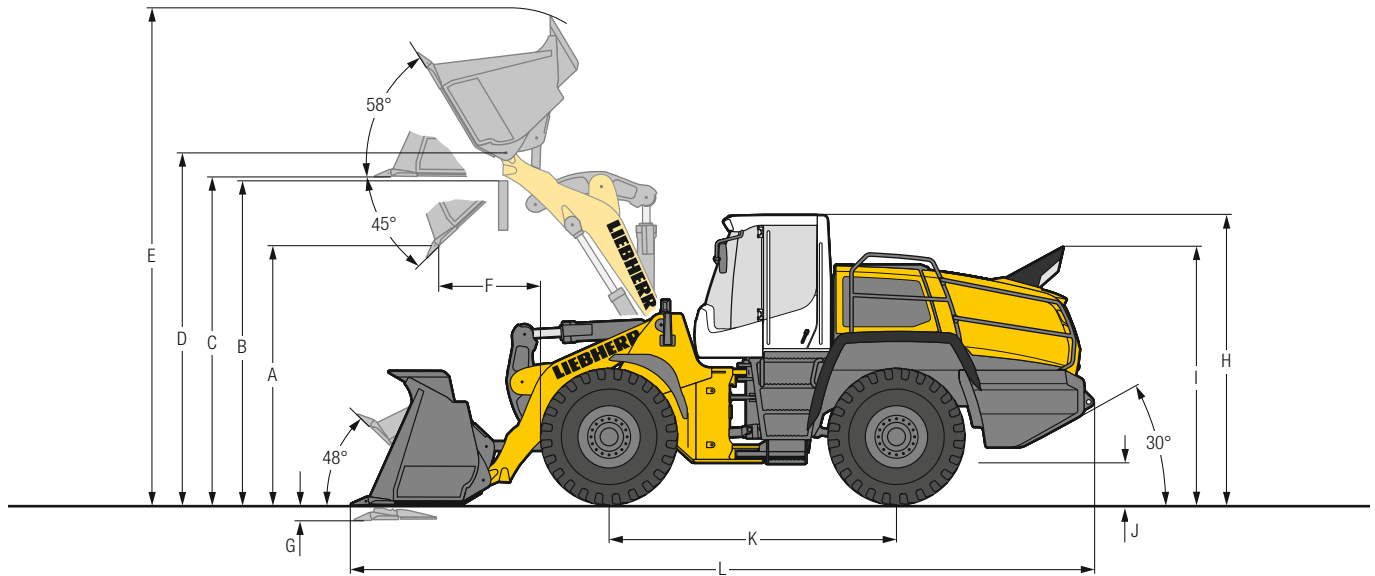

Excavation Bucket



		L 550				L 556			
		STD	STD	HL	HL	STD	STD	HL	HL
Geometry		ZK	ZK	ZK	ZK	ZK	ZK	ZK	ZK
Cutting tools		Z	Z	Z	Z	Z	Z	Z	Z
Lift arm length	ft in	8'10"	8'10"	10'2"	10'2"	8'10"	8'10"	10'2"	10'2"
Bucket capacity according to ISO 7546**	yd ³	4.5	4.8	3.7	4.1	4.8	5.4	4.1	4.4
Specific material density	lb/yd ³	3,034	2,697	3,034	2,697	3,034	2,697	3,034	2,697
Bucket width	ft in	9'5"	9'5"	9'5"	9'5"	9'5"	9'5"	9'5"	9'5"
A Dumping height at max. lift height and 45° discharge	ft in	9'11"	9'9"	12'2"	12'	9'9"	9'6"	12'	11'9"
B Dump-over height	ft in	12'2"	12'2"	13'9"	13'9"	12'2"	12'2"	13'9"	13'9"
C Max. height of bucket bottom	ft in	12'9"	12'9"	14'6"	14'6"	12'9"	12'9"	14'6"	14'6"
D Max. height of bucket pivot point	ft in	4'9"	13'7"	15'5"	15'5"	13'7"	13'7"	15'5"	15'5"
E Max. operating height	ft in	19'	19'3"	20'4"	20'6"	19'3"	19'7"	20'6"	20'10"
F Reach at max. lift height and 45° discharge	ft in	3'4"	3'6"	2'9"	2'11"	3'6"	3'9"	2'11"	3'1"
G Digging depth	ft in	3"	3"	4"	4"	3"	3"	4"	4"
H Height above operator's cab	ft in	11'1"	11'1"	11'1"	11'1"	11'1"	11'1"	11'1"	11'1"
I Height above exhaust	ft in	9'11"	9'11"	9'11"	9'11"	9'11"	9'11"	9'11"	9'11"
J Ground clearance	ft in	1'7"	1'7"	1'7"	1'7"	1'7"	1'7"	1'7"	1'7"
K Wheelbase	ft in	11'6"	11'6"	11'6"	11'6"	11'6"	11'6"	11'6"	11'6"
L Overall length	ft in	28'1"	28'4"	29'6"	29'9"	28'4"	28'8"	29'9"	30'
Turning circle radius over tires	ft in	20'2"	20'2"	20'2"	20'2"	20'2"	20'2"	20'2"	20'2"
Turning circle radius over outside bucket edge	ft in	22'5"	22'6"	23'1"	23'1"	22'6"	22'7"	23'1"	23'2"
Breakout force (SAE)	lbf	37,095	34,845	39,340	37,095	39,340	37,095	41,590	39,340
Tippling load, straight*	lb	30,975	30,755	25,795	25,575	34,390	33,950	28,660	28,440
Tippling load, fully articulated*	lb	27,560	27,335	22,595	22,375	30,315	29,870	25,020	24,800
Operating weight*	lb	40,895	41,115	41,335	41,625	43,210	43,430	43,650	43,760
Tire size		23.5R25 L3				23.5R25 L3			

* The figures shown include the above tires, all lubricants, a full fuel tank, the ROPS/FOPS cab and the operator. Different tires and optional equipment will change the operating weight and tipping load. (Tipping load, fully articulated according to ISO 14397-1)

** Actual bucket capacity may be approx. 10% larger than the calculation according to ISO 7546 standard. The degree to which the bucket can be filled depends on the material – see page 24.

- STD = Standard lift arm length
- HL = High Lift
- ZK = Z-bar linkage
- T = Welded-on tooth holder with add-on teeth

Dimensions

Industrial Lift Arm

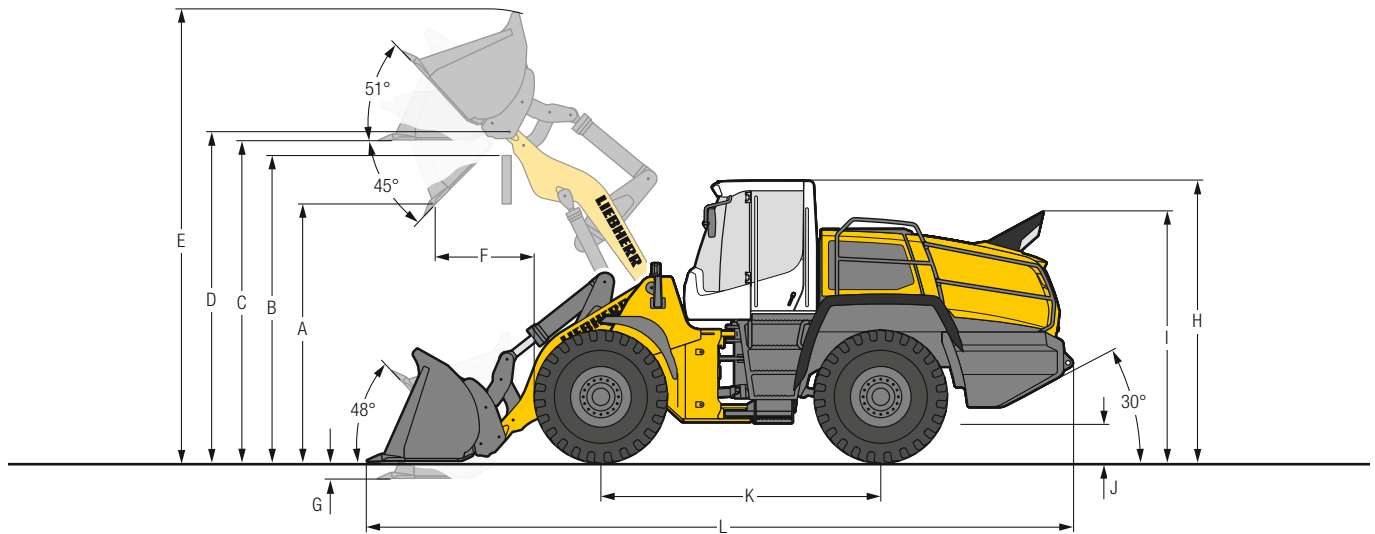

Excavation Bucket

		L 550			L 556		
		STD	HL	HL	STD	HL	HL
Geometry		IND-QC	IND-QC	IND-QC	IND-QC	IND-QC	IND-QC
Cutting tools		T	T	T	T	T	T
Lift arm length	ft in	8'10"	9'10"	9'10"	8'10"	9'10"	9'10"
Bucket capacity according to ISO 7546**	yd ³	4.1	3.4	3.7	4.4	3.7	4.1
Specific material density	lb/yd ³	3,034	3,034	2,697	3,034	3,034	2,697
Bucket width	ft in	9'5"	9'5"	9'5"	9'5"	9'5"	9'5"
A Dumping height at max. lift height and 45° discharge	ft in	9'7"	11'7"	11'5"	9'5"	11'5"	11'3"
B Dump-over height	ft in	12'2"	13'5"	13'5"	12'2"	13'5"	13'5"
C Max. height of bucket bottom	ft in	12'8"	14'5"	14'5"	12'8"	14'5"	14'5"
D Max. height of bucket pivot point	ft in	13'7"	15'4"	15'4"	13'7"	15'4"	15'4"
E Max. operating height	ft in	19'2"	20'6"	20'8"	19'5"	20'8"	20'11"
F Reach at max. lift height and 45° discharge	ft in	3'9"	2'9"	2'10"	4'	2'10"	3'
G Digging depth	ft in	4"	4"	4"	4"	4"	4"
H Height above operator's cab	ft in	11'1"	11'1"	11'1"	11'1"	11'1"	11'1"
I Height above exhaust	ft in	9'11"	9'11"	9'11"	9'11"	9'11"	9'11"
J Ground clearance	ft in	1'7"	1'7"	1'7"	1'7"	1'7"	1'7"
K Wheelbase	ft in	11'6"	11'6"	11'6"	11'6"	11'6"	11'6"
L Overall length	ft in	28'10"	29'7"	29'9"	29'1"	29'9"	30'
Turning circle radius over tires	ft in	20'2"	20'2"	20'2"	20'2"	20'2"	20'2"
Turning circle radius over outside bucket edge	ft in	22'7"	22'11"	23'	22'7"	23'	23'
Breakout force (SAE)	lbf	31,475	33,720	32,595	34,845	39,340	37,095
Tipping load, straight*	lb	28,440	24,690	24,470	31,525	27,335	27,115
Tipping load, fully articulated*	lb	25,130	21,650	21,385	27,560	23,810	23,590
Operating weight*	lb	42,330	42,550	42,660	44,535	44,755	44,865
Tire size		23.5R25 L3			23.5R25 L3		

* The figures shown include the above tires, all lubricants, a full fuel tank, the ROPS/FOPS cab and the operator. Different tires and optional equipment will change the operating weight and tipping load. (Tipping load, fully articulated according to ISO 14397-1)

** Actual bucket capacity may be approx. 10% larger than the calculation according to ISO 7546 standard. The degree to which the bucket can be filled depends on the material – see page 24.

STD = Standard lift arm length

HL = High Lift

IND-QC = Industrial lift arm with parallel guidance incl. quick coupler

T = Welded-on tooth holder with add-on teeth

Attachment

Light Material Bucket

L 550 – L 556

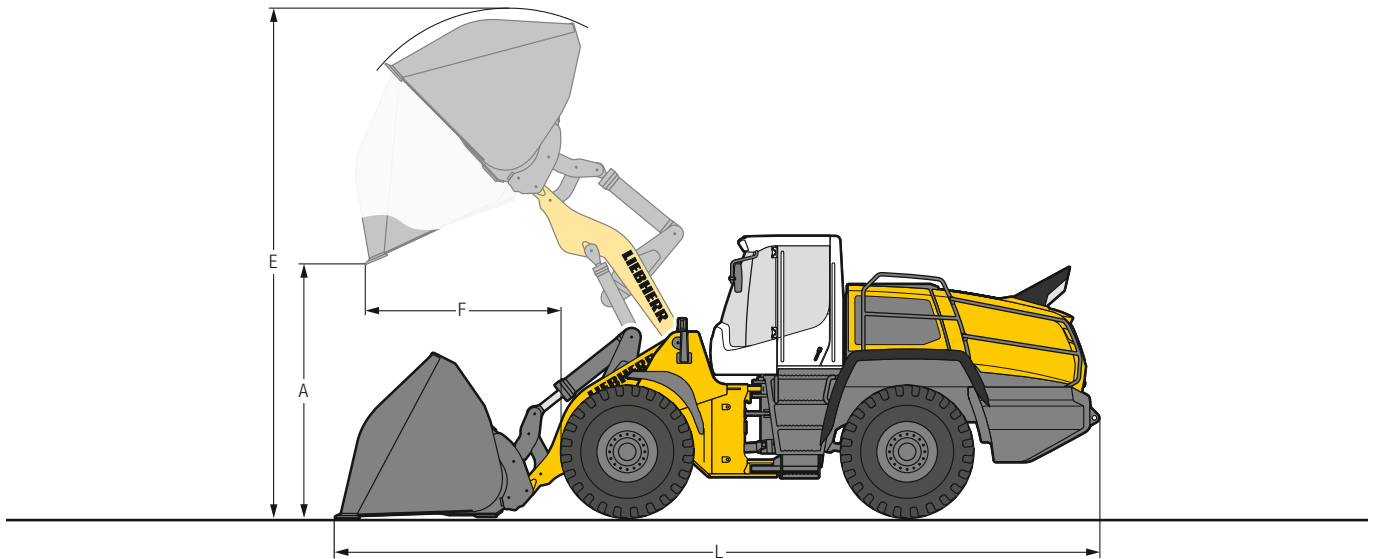

Heavy Material Density

		L 550		L 556	
		STD	HL	STD	HL
Geometry		IND-QC	IND-QC	IND-QC	IND-QC
Cutting tools		BOCE	BOCE	BOCE	BOCE
Bucket capacity	yd ³	6.5	5.9	7.2	6.5
Specific material density	lb/yd ³	1,686	1,686	1,686	1,686
Bucket width	ft in	9'8"	9'8"	9'8"	9'8"
A Dumping height at max. lift height	ft in	8'8"	10'6"	8'4"	10'4"
E Max. operating height	ft in	19'7"	21'6"	19'10"	21'4"
F Reach at maximum lift height	ft in	4'8"	3'8"	4'11"	3'11"
L Overall length	ft in	29'5"	30'4"	29'10"	30'7"
Tipping load, straight*	lb	26,895	23,370	29,985	26,015
Tipping load, fully articulated*	lb	23,370	20,280	25,795	22,485
Operating weight*	lb	42,990	43,210	45,195	45,415
Tire size		23.5R25 L3		23.5R25 L3	



Light Material Density

		L 550		L 556	
		STD	HL	STD	HL
Geometry		IND-QC	IND-QC	IND-QC	IND-QC
Cutting tools		BOCE	BOCE	BOCE	BOCE
Bucket capacity	yd ³	12.4	11.1	13.1	11.8
Specific material density	lb/yd ³	843	843	843	843
Bucket width	ft in	11'2"	11'2"	11'2"	11'2"
A Dumping height at max. lift height	ft in	7'7"	9'7"	7'7"	9'5"
E Max. operating height	ft in	20'6"	22'1"	20'6"	22'2"
F Reach at maximum lift height	ft in	5'9"	4'8"	5'9"	4'10"
L Overall length	ft in	30'11"	31'9"	30'11"	31'11"
Tipping load, straight*	lb	26,235	22,485	29,320	24,910
Tipping load, fully articulated*	lb	22,485	19,400	25,355	21,385
Operating weight*	lb	44,310	44,535	46,515	46,730
Tire size		23.5R25 L3		23.5R25 L3	

* The figures shown include the above tires, all lubricants, a full fuel tank, the ROPS/FOPS cab and the operator. Different tires and optional equipment will change the operating weight and tipping load. (Tipping load, fully articulated according to ISO 14397-1)

- STD = Standard lift arm length
- HL = High Lift
- IND-QC = Industrial lift arm with parallel guidance incl. quick coupler
- BOCE = Bolt-on cutting edge

Attachment

High-Dump Bucket

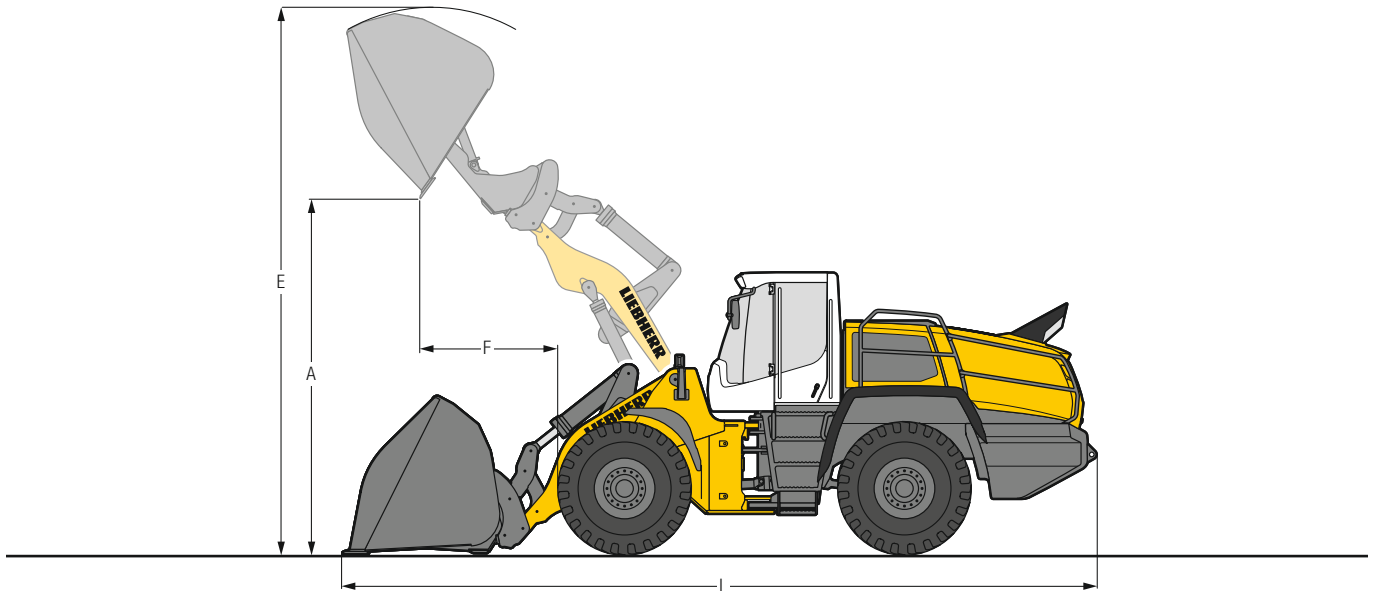

Heavy Material Density

		L 550		L 556	
		STD	HL	STD	HL
Geometry		IND-QC	IND-QC	IND-QC	IND-QC
Cutting tools		BOCE	BOCE	BOCE	BOCE
Bucket capacity	yd ³	5.9	5.2	6.5	5.9
Specific material density	lb/yd ³	1,686	1,686	1,686	1,686
Bucket width	ft in	8'10"	8'10"	8'10"	8'10"
A Dumping height at max. lift height	ft in	15'3"	17'2"	15'	17'
E Max. operating height	ft in	22'6"	24'2"	22'8"	24'3"
F Reach at maximum lift height	ft in	5'6"	4'7"	5'9"	4'9"
L Overall length	ft in	30'4"	31'4"	30'8"	31'6"
Tipping load, straight*	lb	26,235	22,265	29,985	24,910
Tipping load, fully articulated*	lb	22,705	19,180	26,015	21,165
Operating weight*	lb	43,870	44,090	44,975	46,295
Tire size		23.5R25 L3		23.5R25 L3	



Light Material Density

		L 550		L 556	
		STD	HL	STD	HL
Geometry		IND-QC	IND-QC	IND-QC	IND-QC
Cutting tools		BOCE	BOCE	BOCE	BOCE
Bucket capacity	yd ³	11.8	10.5	12.4	11.1
Specific material density	lb/yd ³	843	843	843	843
Bucket width	ft in	11'2"	11'2"	11'2"	11'2"
A Dumping height at max. lift height	ft in	14'3"	16'3"	14'1"	16'1"
E Max. operating height	ft in	23'3"	24'7"	23'5"	24'10"
F Reach at maximum lift height	ft in	5'8"	4'8"	5'9"	4'10"
L Overall length	ft in	30'10"	31'9"	31'1"	32'
Tipping load, straight*	lb	25,130	21,385	28,220	24,030
Tipping load, fully articulated*	lb	21,605	18,300	24,250	20,505
Operating weight*	lb	45,195	45,415	47,400	47,620
Tire size		23.5R25 L3		23.5R25 L3	

* The figures shown include the above tires, all lubricants, a full fuel tank, the ROPS/FOPS cab and the operator. Different tires and optional equipment will change the operating weight and tipping load. (Tipping load, fully articulated according to ISO 14397-1)

- STD = Standard lift arm length
- HL = High Lift
- IND-QC = Industrial lift arm with parallel guidance incl. quick coupler
- BOCE = Bolt-on cutting edge

Attachment

Fork Carrier and Fork

L 550 – L 556

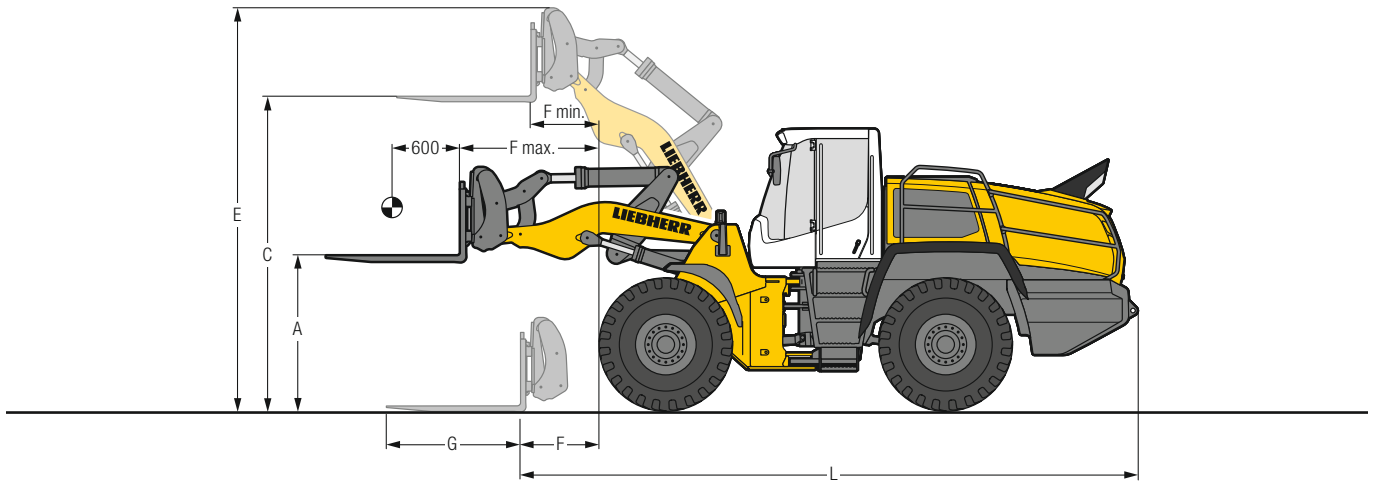

FEM IV Fork Carrier and Fork

		L 550	L 556
Geometry		IND-QC	IND-QC
A	Lifting height at max. reach	ft in	5'11"
C	Max. lifting height	ft in	12'10"
E	Max. operating height	ft in	16'1"
F	Reach at loading position	ft in	3'7"
F max.	Max. reach	ft in	5'7"
F min.	Reach at max. lifting height	ft in	2'4"
G	Fork length	ft in	4'11"
L	Length – basic machine	ft in	24'10"
	Tipping load, straight*	lb	24,120
	Tipping load, fully articulated*	lb	21,230
	Recommended payload for uneven ground = 60% of tipping load, articulated ¹⁾	lb	12,745
	Recommended payload for smooth surfaces = 80% of tipping load, articulated ¹⁾	lb	16,995
	Operating weight*	lb	40,785
	Tire size	23.5R25 L3	23.5R25 L3

* The figures shown include the above tires, all lubricants, a full fuel tank, the ROPS/FOPS cab and the operator. Different tires and optional equipment will change the operating weight and tipping load. (Tipping load, fully articulated according to ISO 14397-1)

¹⁾ According to EN 474-3

IND-QC = Industrial lift arm with parallel guidance incl. quick coupler

Attachment

Log Grapple

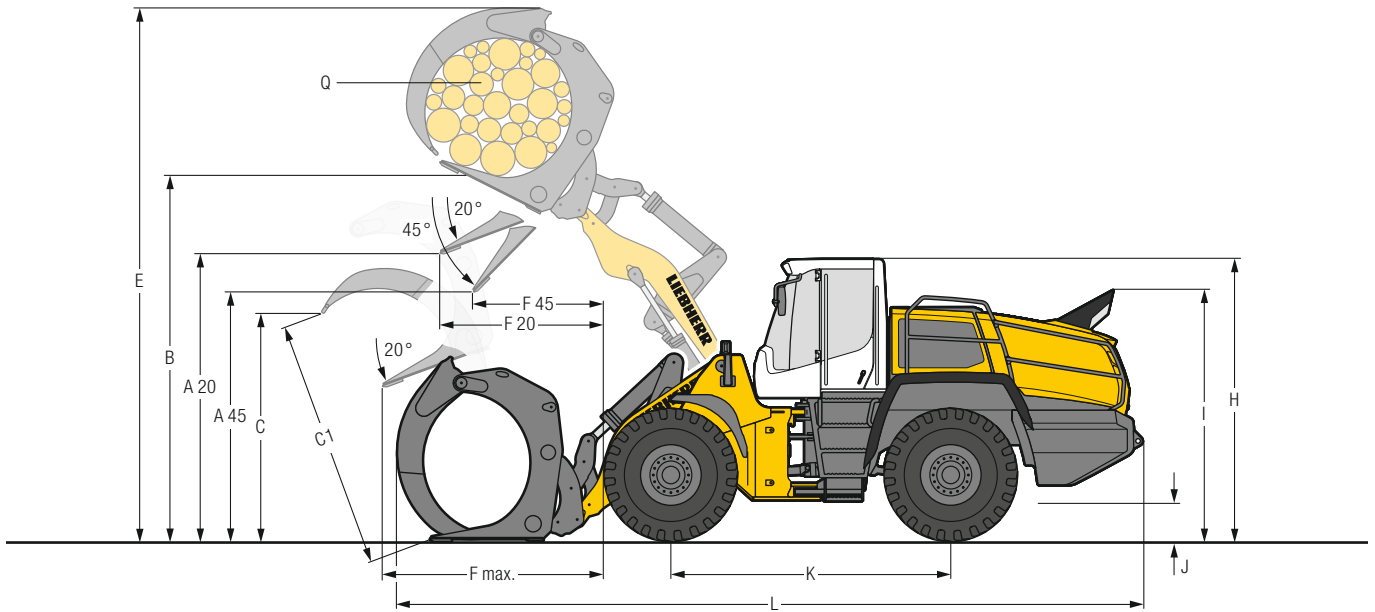

Log Grapple

			L 550	L 556
Geometry			IND-QC	IND-QC
A20	Discharge height at 20°	ft in	11'3"	11'
A45	Discharge height at 45°	ft in	9'8"	9'1"
B	Manipulation height	ft in	14'11"	15'3"
C	Max. grapple opening in loading position	ft in	7'10"	9'
C1	Max. grapple opening	ft in	8'6"	9'10"
E	Max. height	ft in	20'10"	21'10"
F20	Reach at max. lifting height at 20° discharge	ft in	5'3"	5'11"
F45	Reach at max. lifting height at 45° discharge	ft in	3'10"	4'4"
F max.	Max. reach	ft in	8'6"	9'3"
H	Height above operator's cab	ft in	11'2"	11'2"
I	Height above exhaust	ft in	10'	10'
J	Ground clearance	ft in	1'7"	1'7"
K	Wheelbase	ft in	11'6"	11'6"
L	Overall length	ft in	28'10"	29'9"
	Width over tires	ft in	8'8"	8'8"
Q	Grapple diameter	yd ²	2.15	2.85
	Grapple width	ft in	5'3"	5'3"
	Payload*	lb	13,890	14,110
	Operating weight*	lb	44,090	46,295
	Tire size		23.5R25 L4	23.5R25 L4

* The figures shown include the above tires, all lubricants, a full fuel tank, the ROPS/FOPS cab and the operator. Different tires and optional equipment will change the operating weight and payload.

IND-QC = Industrial lift arm with parallel guidance incl. quick coupler

Bucket Selection

		L 550		Material density (lb/yd³)												
Lift arm	Bucket	674	1,011	1,348	1,686	2,023	2,360	2,697	3,034	3,371						
ZK	GPB ₁	4.5 yd³							4.8		4.5					
		4.8 yd³							5.4		4.8					
ZK-HL	GPB ₁	3.7 yd³							4.1		3.7					
		4.1 yd³							4.5		4.1					
IND-QC	GPB ₁	4.1 yd³							4.5		4.1					
		6.5 yd³			7.2						6.5					
	LMB	12.4 yd³	12.4													
		5.9 yd³			6.5						5.9					
HDB	11.8 yd³	11.8														
	5.2 yd³			5.8						5.2						
IND-QC-HL	GPB ₁	3.4 yd³							3.8		3.4					
		3.7 yd³							4.1		3.7					
	LMB	5.9 yd³			6.5						5.9					
		11.1 yd³	11.1													
	HDB	5.2 yd³			5.8						5.2					
		10.5 yd³	10.5													

		L 556		Material density (lb/yd³)												
Lift arm	Bucket	674	1,011	1,348	1,686	2,023	2,360	2,697	3,034	3,371						
ZK	GPB ₁	4.8 yd³							5.4		4.8					
		5.4 yd³							5.9		5.4					
ZK-HL	GPB ₁	4.1 yd³							4.5		4.1					
		4.5 yd³							4.8		4.5					
IND-QC	GPB ₁	4.5 yd³							4.8		4.5					
		7.2 yd³			8.0						7.2					
	LMB	13.1 yd³	13.1													
		6.5 yd³			7.2						6.5					
HDB	12.4 yd³	12.4														
	3.7 yd³								4.1		3.7					
IND-QC-HL	GPB ₁	4.1 yd³							4.5		4.1					
		6.5 yd³			7.2						6.5					
	LMB	11.8 yd³	11.8													
		5.9 yd³			6.5						5.9					
	HDB	11.1 yd³	11.1													
		5.2 yd³			5.8						5.2					

Bucket Filling Factor

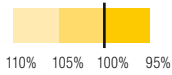

Lift Arm

ZK	Z-bar linkage, standard lift arm length
ZK-HL	Z-bar linkage, High Lift
IND-QC	Industrial lift arm with quick coupler, standard lift arm length
IND-QC-HL	Industrial lift arm with quick coupler, High Lift

Bucket

GPB₁	General purpose bucket (Excavation bucket)
LMB	Light material bucket
HDB	High-dump bucket

Bulk Material Densities and Bucket Filling Factors

		lb/yd³	%			lb/yd³	%			lb/yd³	%
Gravel	moist	3,203	105	Earth	dry	2,191	115	Glass waste	broken	2,360	100
	dry	2,697	105		wet excavated	2,697	110		solid	1,686	100
	crushed stone	2,528	100	Topsoil		1,854	110		Compost	dry	1,348
Sand	dry	2,528	105	Basalt		3,287	100		wet	1,686	110
	wet	3,203	110	Granite		3,034	95	Wood chips/Saw dust		843	110
Gravel and Sand	dry	2,865	105	Sandstone		2,697	100	Paper	shredded/loose	1,011	110
	wet	3,371	100	Slate		2,950	100		recovered paper/cardboard	1,686	110
Sand/Clay		2,697	110	Bauxite		2,360	100	Coal	heavy material density	2,023	110
Clay	natural	2,697	110	Limestone		2,697	100		light material density	1,517	110
	dry	2,360	110	Gypsum	broken	3,034	100	Waste	domestic waste	843	100
Clay/Gravel	dry	2,360	110	Coke		843	110		bulky waste	1,686	100
	wet	2,697	100	Slag	broken	3,034	100				

Tires



Tire Types

	Size and tread code		Change of operating weight lb	Width over tires ft in	Change in vertical dimensions* ft in	Use
L 550 XPower® / L 556 XPower®						
Bridgestone	23.5R25 VJT	L3	304	8'9"	0.24"	Bulk material (firm ground conditions)
Bridgestone	23.5R25 VLTS	L4	794	8'9"	1.54"	Gravel, Industry (firm ground conditions)
Bridgestone	23.5R25 VSDL	L5	1,980	8'9"	2.56"	Stone, Scrap, Recycling (firm ground conditions)
Bridgestone	23.5R25 VSDT	L5	1,876	8'9"	2.17"	Stone, Scrap, Recycling (firm ground conditions)
Bridgestone	650/65R25 VTS	L3	9	8'10"	- 1.18"	Gravel (all ground conditions)
Bridgestone	750/65R25 VTS	L3	1,605	9'5"	0.43"	Gravel, Industry, Wood (all ground conditions)
Continental	23.5R25 EM-Master	L3	467	8'9"	1.14"	Bulk material (firm ground conditions)
Continental	23.5R25 EM-Master	L4	732	8'9"	0.79"	Gravel, Industry, Wood (firm ground conditions)
Goodyear	23.5R25 RT-3B	L3	414	8'9"	0.79"	Gravel (all ground conditions)
Goodyear	23.5R25 TL-3A+	L3	626	8'9"	1.42"	Sand, Gravel, Earthworks, Clay (all ground conditions)
Goodyear	23.5R25 GP-4D	L4	723	8'10"	0.98"	Gravel, Industry, Wood (firm ground conditions)
Goodyear	23.5R25 RL-4K	L4	1,102	8'10"	1.54"	Gravel, Industry, Stone (firm ground conditions)
Goodyear	23.5R25 RL-5K	L5	2,064	8'10"	2.24"	Stone, Scrap, Recycling (firm ground conditions)
Goodyear	23.5R25 RL-5S	L5	2,134	8'10"	2.24"	Scrap, Recycling, Slag (firm ground conditions)
Goodyear	23.5R25 RT-5D	L5	1,808	8'9"	2.17"	Stone, Mining spoil (firm ground conditions)
Goodyear	750/65R25 TL-3A+	L3	1,499	9'7"	0.94"	Sand, Gravel, Industry, Wood (all ground conditions)
Michelin	23.5R25 XHA2	L3	0	8'8"	0"	Sand, Gravel (all ground conditions)
Michelin	23.5R25 XTLA	L2	- 26	8'8"	- 0.16"	Gravel, Earthworks, Clay (all ground conditions)
Michelin	23.5R25 X MINE PRO	L5	1,825	8'10"	2.20"	Stone, Scrap, Recycling (firm ground conditions)
Michelin	23.5R25 XLD D2A	L5	1,349	8'9"	1.02"	Stone, Mining spoil (firm ground conditions)
Michelin	650/65R25 XLD65	L3T	- 247	8'10"	- 2.09"	Gravel, Industry, Wood (all ground conditions)
Michelin	750/65R25 XLD65	L3T	1,155	9'5"	- 0.28"	Gravel, Industry, Wood (all ground conditions)

* The stated values are theoretical and may deviate in practice.

Before operating the vehicle with tire foam filling or tire protection chains, please discuss this with the Liebherr-Werk Bischofshofen GmbH.

Technical Data



Motor

	L 566	L 580	L 586
Diesel engine	D936 A7	D936 A7	D936 A7
Design	Water-cooled in-line engine with charge-air cooling		
Cylinder inline	6	6	6
Fuel injection process	Electronic Common Rail high-pressure injection		
Output			
to ISO 9249/ ECE-R.24	kW/HP 200/268 at RPM 1,800	230/308 1,800	260/349 1,800
Rated output to ISO 14396/ ECE-R.120	kW/HP 203/272 at RPM 1,800	233/312 1,800	263/353 1,800
Nominal speed	at RPM 1,800		
Max. torque to ISO 14396/ ECE-R.120	lb ft 1,412 at RPM 1,000	1,452 1,000	1,452 1,000
Displacement	in ³ 642		
Bore/Stroke	ft in 4.8"/5.91"		
Tier 4f			
Harmful emissions values	In accordance with EPA 40 CFR part 1039 and CARB 13 CCR section 2423		
Emission control	Liebherr-SCR technology		
Fuel tank	gal 96	96	132
DEF tank	gal 17.8	17.8	17.8
Air cleaner system	Dry type filter with main and safety element, pre-cleaner, service indicator on the Liebherr display		
Electrical system			
Operating voltage	V 24	24	24
Capacity	Ah 2 x 180	2 x 180	2 x 180
Alternator	V/A 28/180	28/180	28/180
Starter	V/HP 24/10.5	24/10.5	24/10.5



Driveline

Continuous power split XPower® driveline	
Design	Continuous, fully-automatic XPower® driveline. No traction interruptions across the entire speed range. Hydrostatic power split with two axial piston units. Identical driving performance – forwards and in reverse
Filtration	Filter system for driveline, depend on working hydraulics
Control	Driveline is controlled from travel pedal for tractive force and speed setting with integrated inch function. The Liebherr control switch is used to control forward and reverse travel
Travel speed range	L 566 – L 580: 0 – 24.9 mph forward and reverse, fully-automatic L 586: 0 – 20.5 mph forward and reverse, fully-automatic Speed restriction available upon request. Speeds quoted apply with the standard tires as indicated on loader model.

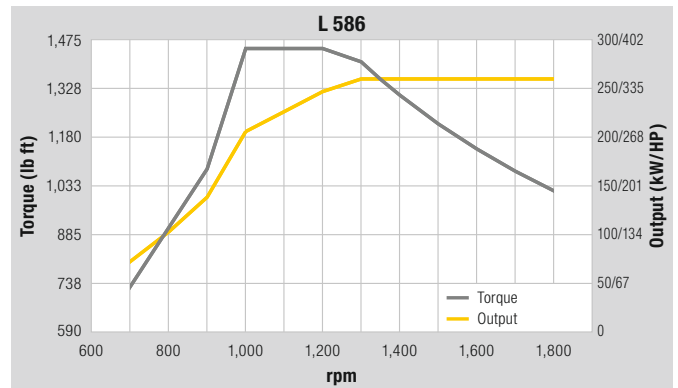
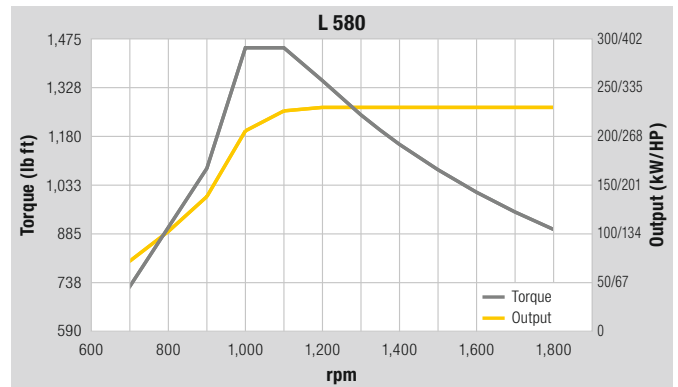
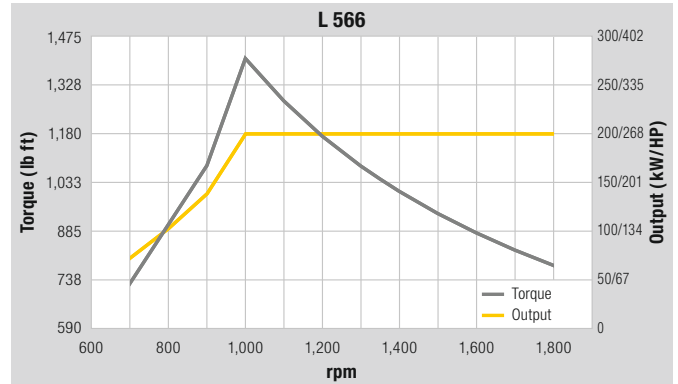

Axles

	L 566	L 580	L 586
Four-wheel drive			
Front axle	Fixed		
Rear axle	Center pivot, with 13° oscillating angle to each side		
Height of obstacles which can be driven over	ft in 1'7.4"	1'6.6"	1'8.6"
	with all four wheels remaining in contact with the ground		
Differentials	Automatic limited-slip differentials		
Reduction gear	Planetary final drive in wheel hubs		
Track width	7'4" with all types of tires (L 566, L 580) 8' with all types of tires (L 586)		



Brakes

Wear-free service brake	Self-locking of the XPower® driveline (acting on all four wheels) and additional pump-accumulator brake system with wet multi-disc brakes (two separate brake circuits)
Parking brake	Electro-hydraulically actuated spring-loaded disc brake system on the transmission

The braking system meets the requirements of the ISO 3450.



Steering

Design	"Load-sensing" swash plate type variable flow pump with pressure cut-off and flow control. Central pivot with two double-acting, damped steering cylinders
Angle of articulation	38° to each side (L 566, L 580) 37° to each side (L 586)
Emergency steering	Electro-hydraulic emergency steering system



Attachment Hydraulics

	L 566	L 580	L 586
Design	"Load-sensing" swash plate type variable flow pump with output and flow control, and pressure cut-off in the control block		
Cooling	Hydraulic oil cooling using thermostatically controlled fan and oil cooler		
Filtration	Return line filter in the hydraulic reservoir		
Control	Liebherr control lever, electro-hydraulically operated		
Lifting function	Lifting, neutral, lowering Automatic lift arm position and lowering by Liebherr control lever Float position controlled by Liebherr control lever		
Tilt function	Tilt back, neutral, dump Automatic bucket return for tilting back and dumping controlled by Liebherr control lever		
Max. flow	gpm 77	84	108
Max. pressure			
Z-bar linkage	psi 5,076	5,511	5,076
Industrial lift arm	psi 5,511	5,511	



Attachment

	L 566	L 580	L 586
Geometry variants			
Optional	Powerful Z-bar linkage with tilt cylinder and cast steel cross-tube Industrial lift arm with tilt cylinder, hydraulic quick coupler standard (L 566, L 580)		
Bearings	Sealed		
Cycle time at nominal load	ZK	IND	ZK
Lifting	s 6.1	6.1	6.2
Dumping	s 1.2	2.0	1.4
Lowering (empty)	s 3.2	3.2	3.4



Operator's Cab

Design	Hydraulically mounted, noise-proof cab ROPS roll over protection per EN ISO 3471 / EN 474-1 FOPS falling objects protection per EN ISO 3449 / EN 474-1, Cat. II Operator's door with sliding side window, sliding side window on right, front windscreen made of compound safety glass, side panels with single-pane safety glass ESG, heated rear window ESG, all windows are tinted. 3 way continuous adjustable steering column
Liebherr operator's seat	6 way adjustable, vibration-damped operator's seat "Comfort" with seat, depth and incline adjustment standard (air-cushioned with seat heating adjustable to operator's weight), Liebherr control lever mounted into the operator's seat standard
Cab heating and ventilation	4-zone air conditioning with new improved cooling output standard, electrically heated rear window, all filters are easy to access and replaceable



Sound Level

	L 566	L 580	L 586
Sound pressure level to ISO 6396			
L _{pA} (inside cab)	dB(A) 68	68	68
Sound power level to 2000/14/EC			
L _{WA} (surround noise)	dB(A) 105	105	107



Capacities

	L 566	L 580	L 586
Engine oil (inclusive filter change)	gal 11.1	11.1	11.1
Pump distribution gearbox	gal 0.3	0.3	0.3
XPower® gearbox	gal 14.5	14.5	14.5
Coolant	gal 19.3	19.3	19.3
Front axle	gal 11.1	15.3	15.9
Rear axle	gal 11.1	15.3	15.9
Hydraulic tank	gal 27.7	27.7	25.1
Hydraulic system, total	gal 50.2	50.2	55.5
Air conditioning system R134a	lb 2.8	2.8	2.8

Dimensions

Z-bar Linkage

L 566 – L 586

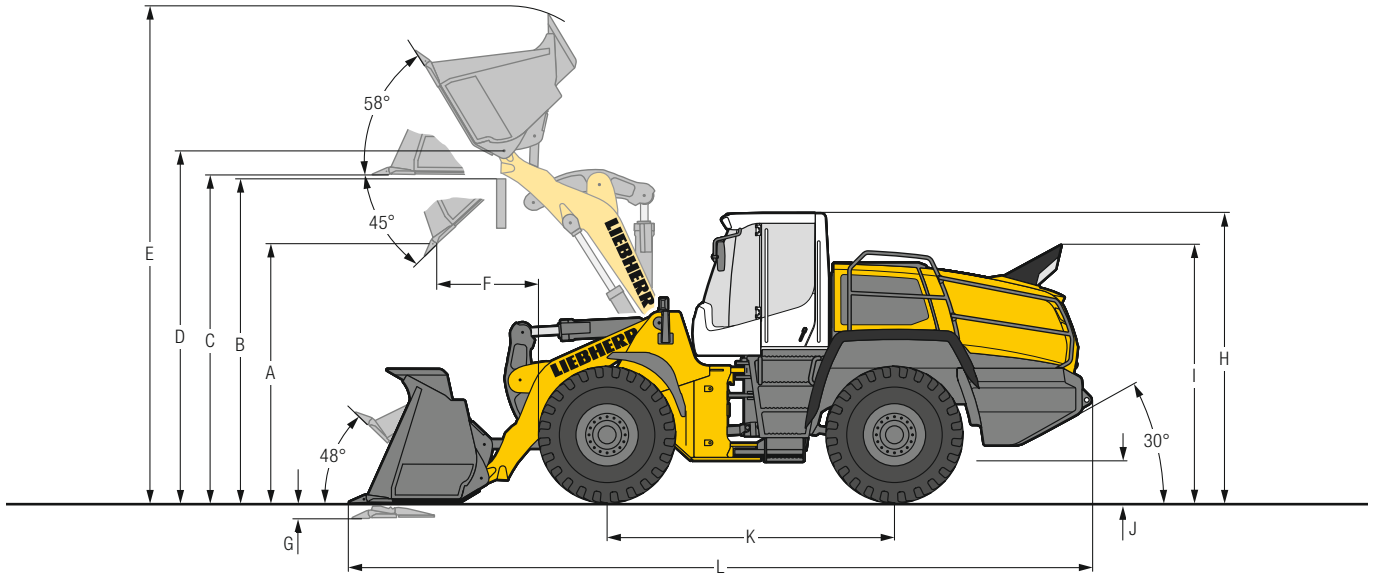

Excavation Bucket



	L 566			L 580			L 586		
Geometry	ZK	ZK	ZK	ZK	ZK	ZK	ZK	ZK	
Cutting tools	T	T	T	T	BOCE	T	T	ROB	
Lift arm length	ft in 9'7"	9'7"	10'	10'	10'	10'4"	10'4"	10'4"	
Bucket capacity according to ISO 7546**	yd ³ 5.5	6.1	6.8	7.5	7.5 ¹⁾	7.8	8.5	7.2	
Specific material density	lb/yd ³ 3,034	2,697	3,034	2,697	2,865	3,034	2,697	3,034	
Bucket width	ft in 9'10"	9'10"	9'10"	10'10"	10'10"	11'3"	12'	11'2"	
A Dumping height at max. lift height and 45° discharge	ft in 10'6"	10'3"	10'9"	10'7"	10'7"	10'8"	10'8"	10'10"	
B Dump-over height	ft in 12'10"	12'10"	13'5"	13'5"	13'5"	13'7"	13'7"	13'7"	
C Max. height of bucket bottom	ft in 13'3"	13'3"	14'	14'	14'	14'2"	14'2"	14'1"	
D Max. height of bucket pivot point	ft in 14'4"	14'4"	15'	15'	15'	15'3"	15'3"	15'3"	
E Max. operating height	ft in 20'1"	20'5"	21'5"	21'4"	21'4"	21'5"	21'5"	21'2"	
F Reach at max. lift height and 45° discharge	ft in 3'11"	4'2"	3'11"	4'3"	4'3"	4'8"	4'8"	4'7"	
G Digging depth	ft in 4"	4"	4"	4"	4"	4"	4"	6"	
H Height above operator's cab	ft in 11'9"	11'9"	11'9"	11'9"	11'9"	12'3"	12'3"	12'4"	
I Height above exhaust	ft in 10'6"	10'6"	10'6"	10'6"	10'6"	10'10"	10'10"	10'11"	
J Ground clearance	ft in 1'9"	1'9"	1'6"	1'6"	1'6"	1'11"	1'11"	1'11"	
K Wheelbase	ft in 11'8"	11'8"	12'2"	12'2"	12'2"	12'10"	12'10"	12'10"	
L Overall length	ft in 30'1"	30'5"	31'7"	31'11"	31'11"	32'9"	32'9"	32'9"	
Turning circle radius over tires	ft in 21'11"	21'11"	22'7"	22'7"	22'7"	24'7"	24'7"	24'9"	
Turning circle radius over outside bucket edge	ft in 24'1"	24'2"	25'	25'6"	25'6"	27'5"	27'7"	27'3"	
Breakout force (SAE)	lbf 44,960	42,715	50,580	46,085	44,960	53,955	53,955	55,080	
Tipping load, straight*	lb 40,015	39,460	47,950	46,850	48,940	54,015	52,690	56,440	
Tipping load, fully articulated*	lb 35,055	34,500	42,330	41,225	42,990	47,620	46,295	49,605	
Operating weight*	lb 52,690	52,910	60,955	61,290	63,490	71,870	72,860	74,295	
Tire size	26.5R25 L3			26.5R25 L3			29.5R25 L3		

* The figures shown include the above tires, all lubricants, a full fuel tank, the ROPS/FOPS cab and the operator. Different tires and optional equipment will change the operating weight and tipping load. (Tipping load, fully articulated according to ISO 14397-1)

** Actual bucket capacity may be approx. 10% larger than the calculation according to ISO 7546 standard. The degree to which the bucket can be filled depends on the material – see pages 34/35.

¹⁾ Toothed buckets, hydraulic quick coupler and additional hydraulic circuits are not approved for rehandling application.



= Excavation bucket with back grading edge for direct mounting



= Rehandling bucket for direct mounting



= Rock bucket with oblique base for quarrying applications for direct mounting

ZK = Z-bar linkage

T = Welded-on tooth holder with add-on teeth

BOCE = Bolt-on cutting edge

ROB = Rock bucket with delta cutting edge, welded-on tooth holder with add-on teeth and bolted intermediate sections

Dimensions

Z-bar Linkage High Lift

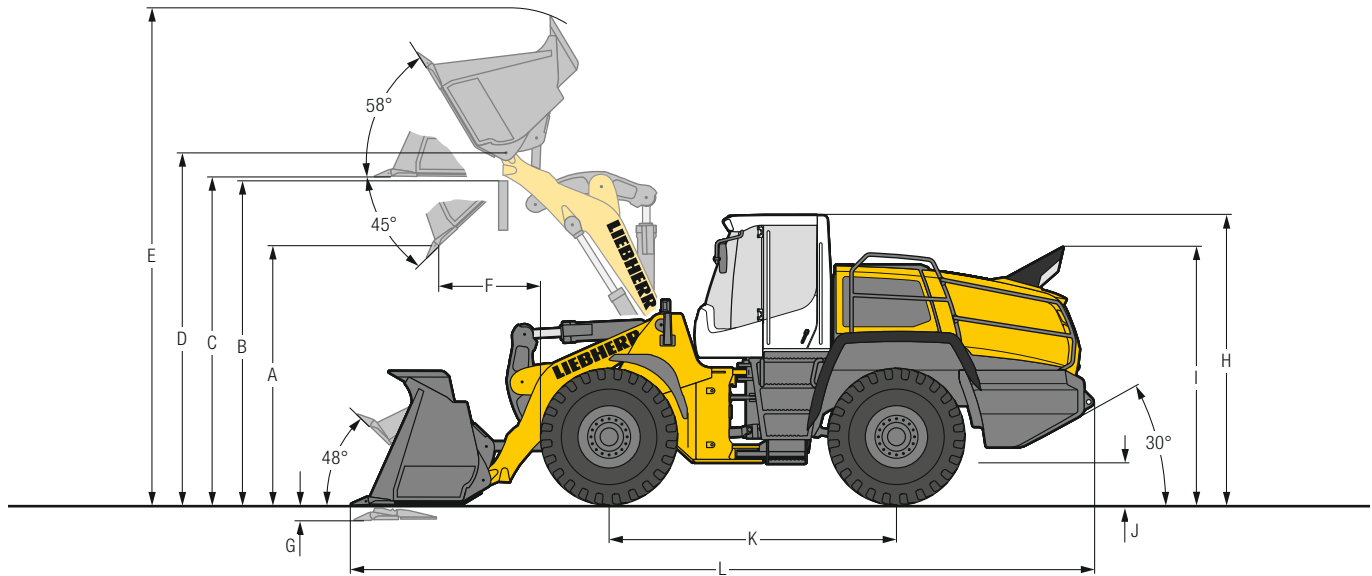

Loading Bucket

	L 566			L 580			L 586		
Geometry	ZK	ZK	ZK	ZK	ZK	ZK	ZK	ZK	
Cutting tools	T	T	T	T	BOCE	T	T	ROB	
Lift arm length	ft in 10'8"	10'8"	10'8"	10'8"	10'8"	11'4"	11'4"	11'4"	
Bucket capacity according to ISO 7546**	yd ³ 4.8	5.5	6.1	6.8	6.8 ¹⁾	7.2	7.8	6.5	
Specific material density	lb/yd ³ 3,034	2,697	3,034	2,697	2,865	3,034	2,697	3,034	
Bucket width	ft in 9'10"	9'10"	9'10"	9'10"	9'10"	11'2"	11'2"	11'2"	
A Dumping height at max. lift height and 45° discharge	ft in 12'2"	12'	11'8"	11'5"	11'3"	12'3"	12'	12'3"	
B Dump-over height	ft in 14'1"	14'1"	14'1"	14'1"	14'1"	14'9"	14'9"	14'9"	
C Max. height of bucket bottom	ft in 14'8"	14'8"	14'8"	14'8"	14'8"	15'7"	15'7"	15'8"	
D Max. height of bucket pivot point	ft in 15'8"	15'8"	15'8"	15'8"	15'8"	16'7"	16'7"	16'8"	
E Max. operating height	ft in 21'2"	21'6"	21'10"	22'1"	22'	22'10"	22'11"	22'4"	
F Reach at max. lift height and 45° discharge	ft in 3'8"	3'11"	3'11"	4'2"	4'5"	4'6"	4'8"	4'6"	
G Digging depth	ft in 6"	6"	6"	6"	6"	4"	4"	6"	
H Height above operator's cab	ft in 11'9"	11'9"	11'9"	11'9"	11'9"	12'3"	12'3"	12'4"	
I Height above exhaust	ft in 10'6"	10'6"	10'6"	10'6"	10'6"	10'10"	10'10"	10'11"	
J Ground clearance	ft in 1'9"	1'9"	1'6"	1'6"	1'6"	1'11"	1'11"	1'11"	
K Wheelbase	ft in 11'8"	11'8"	12'2"	12'2"	12'2"	12'10"	12'10"	12'10"	
L Overall length	ft in 31'2"	31'6"	32'1"	32'5"	32'9"	33'8"	33'9"	33'10"	
Turning circle radius over tires	ft in 21'11"	21'11"	22'7"	22'7"	22'7"	24'7"	24'7"	24'9"	
Turning circle radius over outside bucket edge	ft in 24'6"	24'8"	25'2"	25'4"	25'5"	27'11"	28'1"	27'9"	
Breakout force (SAE)	lbf 47,210	44,960	53,955	50,580	50,580	56,200	53,955	58,450	
Tipping load, straight*	lb 34,945	34,500	44,535	44,090	45,415	49,385	47,840	50,045	
Tipping load, fully articulated*	lb 30,535	30,095	39,240	38,800	40,125	43,430	41,885	44,090	
Operating weight*	lb 52,910	53,130	60,955	61,180	63,050	71,870	72,750	74,735	
Tire size	26.5R25 L3			26.5R25 L3			29.5R25 L3		

* The figures shown include the above tires, all lubricants, a full fuel tank, the ROPS/FOPS cab and the operator. Different tires and optional equipment will change the operating weight and tipping load. (Tipping load, fully articulated according to ISO 14397-1)

** Actual bucket capacity may be approx. 10% larger than the calculation according to ISO 7546 standard. The degree to which the bucket can be filled depends on the material – see pages 34/35.

¹⁾ Toothed buckets, hydraulic quick coupler and additional hydraulic circuits are not approved for rehandling application.



= Excavation bucket with back grading edge for direct mounting



= Rehandling bucket for direct mounting



= Rock bucket with oblique base for quarrying applications for direct mounting

ZK = Z-bar linkage

T = Welded-on tooth holder with add-on teeth

BOCE = Bolt-on cutting edge

ROB = Rock bucket with delta cutting edge, welded-on tooth holder with add-on teeth and bolted intermediate sections

Dimensions

Industrial Lift Arm

L 566 – L 586

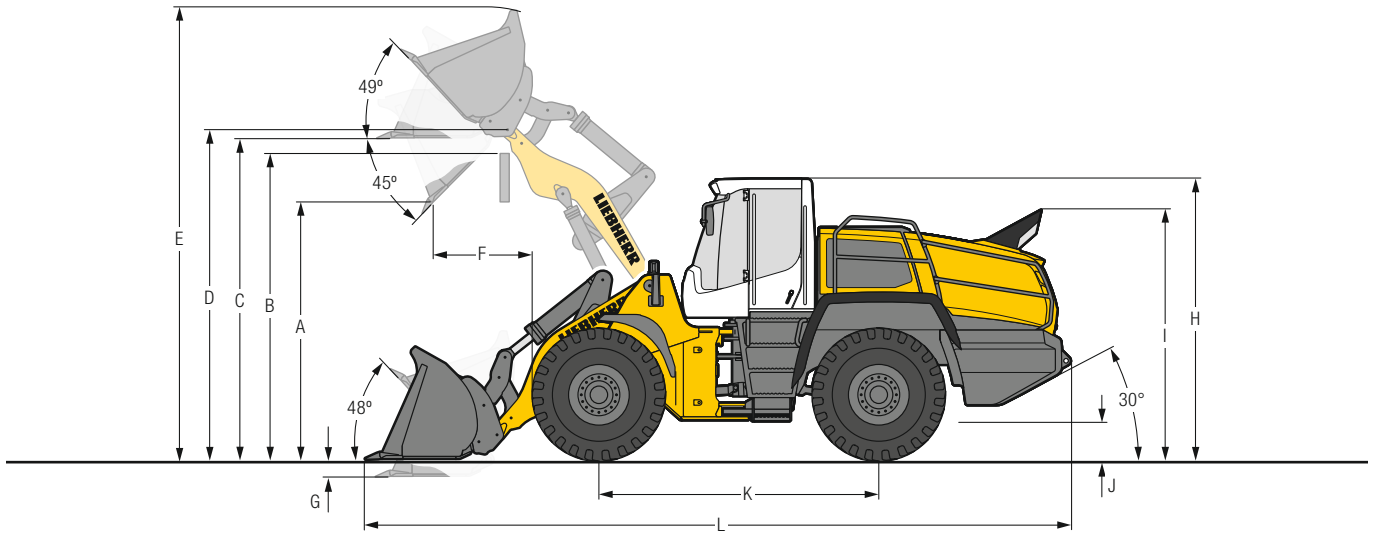

Excavation Bucket

		L 566		L 580	
		IND-QC	IND-QC	IND-QC	IND-QC
Geometry					
Cutting tools		T	T	T	T
Lift arm length	ft in	9'6"	9'6"	9'6"	9'6"
Bucket capacity according to ISO 7546**	yd ³	4.6	5.2	5.9	6.5
Specific material density	lb/yd ³	3,034	2,697	3,034	2,697
Bucket width	ft in	9'10"	9'10"	9'10"	9'10"
A Dumping height at max. lift height and 45° discharge	ft in	10'6"	10'4"	10'1"	9'10"
B Dump-over height	ft in	12'10"	12'10"	12'10"	12'10"
C Max. height of bucket bottom	ft in	13'7"	13'7"	13'7"	13'7"
D Max. height of bucket pivot point	ft in	14'9"	14'9"	14'9"	14'9"
E Max. operating height	ft in	19'10"	20'3"	20'7"	20'9"
F Reach at max. lift height and 45° discharge	ft in	4'2"	4'5"	4'3"	4'
G Digging depth	ft in	4"	4"	4"	4"
H Height above operator's cab	ft in	11'9"	11'9"	11'9"	11'9"
I Height above exhaust	ft in	10'6"	10'6"	10'6"	10'6"
J Ground clearance	ft in	1'9"	1'9"	1'6"	1'6"
K Wheelbase	ft in	11'11"	11'11"	12'2"	12'2"
L Overall length	ft in	30'5"	30'9"	31'4"	31'8"
Turning circle radius over tires	ft in	22'3"	22'3"	22'7"	22'7"
Turning circle radius over outside bucket edge	ft in	24'4"	24'5"	24'10"	24'11"
Breakout force (SAE)	lbf	44,960	41,590	44,960	41,590
Tipping load, straight*	lb	37,700	36,705	44,425	43,430
Tipping load, fully articulated*	lb	33,070	32,075	39,130	38,140
Operating weight*	lb	54,675	55,005	61,840	62,170
Tire size		26.5R25 L3		26.5R25 L3	

* The figures shown include the above tires, all lubricants, a full fuel tank, the ROPS/FOPS cab and the operator. Different tires and optional equipment will change the operating weight and tipping load. (Tipping load, fully articulated according to ISO 14397-1)

** Actual bucket capacity may be approx. 10% larger than the calculation according to ISO 7546 standard. The degree to which the bucket can be filled depends on the material – see pages 34/35.

IND-QC = Industrial lift arm with parallel guidance incl. quick coupler

T = Welded-on tooth holder with add-on teeth

Attachment

Light Material Bucket and High-Dump Bucket

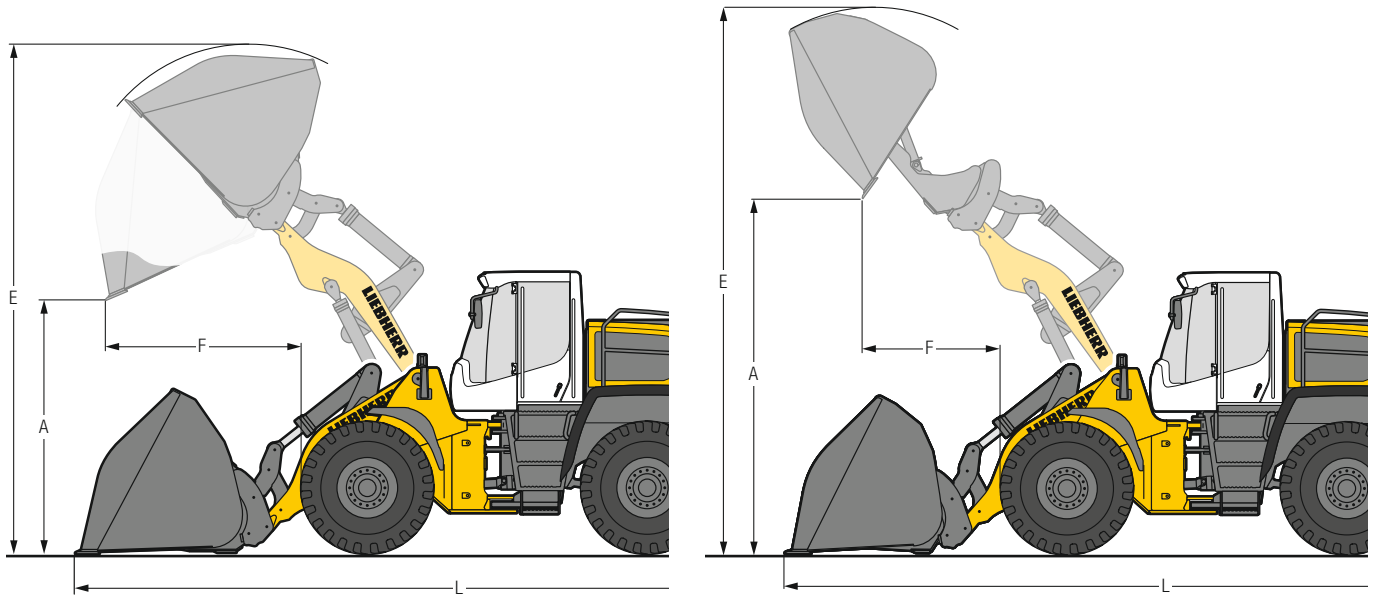

L 566 – L 586

Light Material Bucket

	L 566		L 580		L 586
Geometry	IND-QC	IND-QC	IND-QC	IND-QC	ZK
Cutting tools	BOCE	BOCE	BOCE	BOCE	BOCE
Bucket capacity	yd ³	8.5	15.7	9.8	18.3
Specific material density	lb/yd ³	1,686	758	1,686	758
Bucket width	ft in	10'6"	12'2"	11'2"	13'1"
A Dumping height at max. lift height	ft in	9'6"	8'7"	9'3"	8'2"
E Max. operating height	ft in	21'3"	22'	21'7"	22'4"
F Reach at maximum lift height	ft in	4'10"	6'1"	5'1"	6'5"
L Overall length	ft in	31'4"	32'11"	31'10"	33'6"
Tipping load, straight*	lb	34,610	32,185	30,645	39,460
Tipping load, fully articulated*	lb	30,205	27,780	37,260	34,170
Operating weight*	lb	55,885	57,980	63,160	65,255
Tire size		26.5R25 L3		26.5R25 L3	29.5R25 L3

High-Dump Bucket

	L 566		L 580		L 586
Geometry	IND-QC	IND-QC	IND-QC	IND-QC	ZK
Cutting tools	BOCE	BOCE	BOCE	BOCE	BOCE
Bucket capacity	yd ³	7.8	14.4	9.2	17.0
Specific material density	lb/yd ³	1,686	758	1,686	758
Bucket width	ft in	10'6"	12'2"	10'6"	13'1"
A Dumping height at max. lift height	ft in	16'10"	15'11"	16'4"	15'8"
E Max. operating height	ft in	23'8"	24'7"	24'4"	25'1"
F Reach at maximum lift height	ft in	5'10"	7'	6'8"	6'9"
L Overall length	ft in	32'2"	33'3"	33'	33'10"
Tipping load, straight*	lb	32,410	31,085	39,240	37,700
Tipping load, fully articulated*	lb	28,000	26,675	34,170	32,630
Operating weight*	lb	57,320	59,305	64,155	66,360
Tire size		26.5R25 L3		26.5R25 L3	29.5R25 L3

* The figures shown include the above tires, all lubricants, a full fuel tank, the ROPS/FOPS cab and the operator. Different tires and optional equipment will change the operating weight and tipping load. (Tipping load, fully articulated according to ISO 14397-1)

IND-QC = Industrial lift arm with parallel guidance incl. quick coupler
 ZK = Z-bar linkage
 BOCE = Bolt-on cutting edge

Attachment

Fork Carrier and Fork

L 566 – L 586

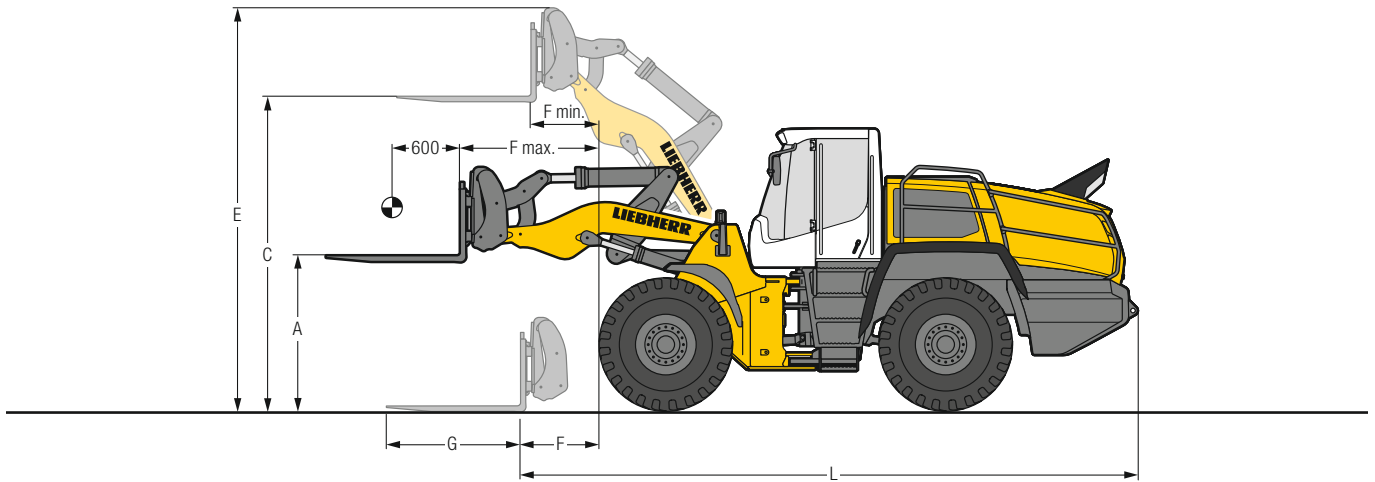

FEM IV Fork Carrier and Fork

		L 566	L 580
Geometry		IND-QC	IND-QC
A	Lifting height at max. reach ft in	6'10"	6'10"
C	Max. lifting height ft in	13'9"	13'10"
E	Max. operating height ft in	17'1"	17'1"
F	Reach at loading position ft in	3'9"	3'4"
F max.	Max. reach ft in	6'4"	5'11"
F min.	Reach at max. lifting height ft in	3'3"	2'10"
G	Fork length ft in	5'11"	5'11"
L	Length – basic machine ft in	26'7"	26'10"
	Tipping load, straight* lb	29,760	35,935
	Tipping load, fully articulated* lb	26,235	31,745
	Recommended payload for uneven ground = 60% of tipping load, articulated ¹⁾ lb	15,740	19,050
	Recommended payload for smooth surfaces = 80% of tipping load, articulated ¹⁾ lb	20,990	22,045 ²⁾
	Operating weight* lb	52,800	59,305
	Tire size	26.5R25 L3	26.5R25 L3

* The figures shown include the above tires, all lubricants, a full fuel tank, the ROPS/FOPS cab and the operator. Different tires and optional equipment will change the operating weight and tipping load. (Tipping load, fully articulated according to ISO 14397-1)

¹⁾ According to EN 474-3

²⁾ Payload is limited by FEM IV fork carrier and forks

IND-QC = Industrial lift arm with parallel guidance incl. quick coupler

Attachment

Log Grapple

L 566 – L 586

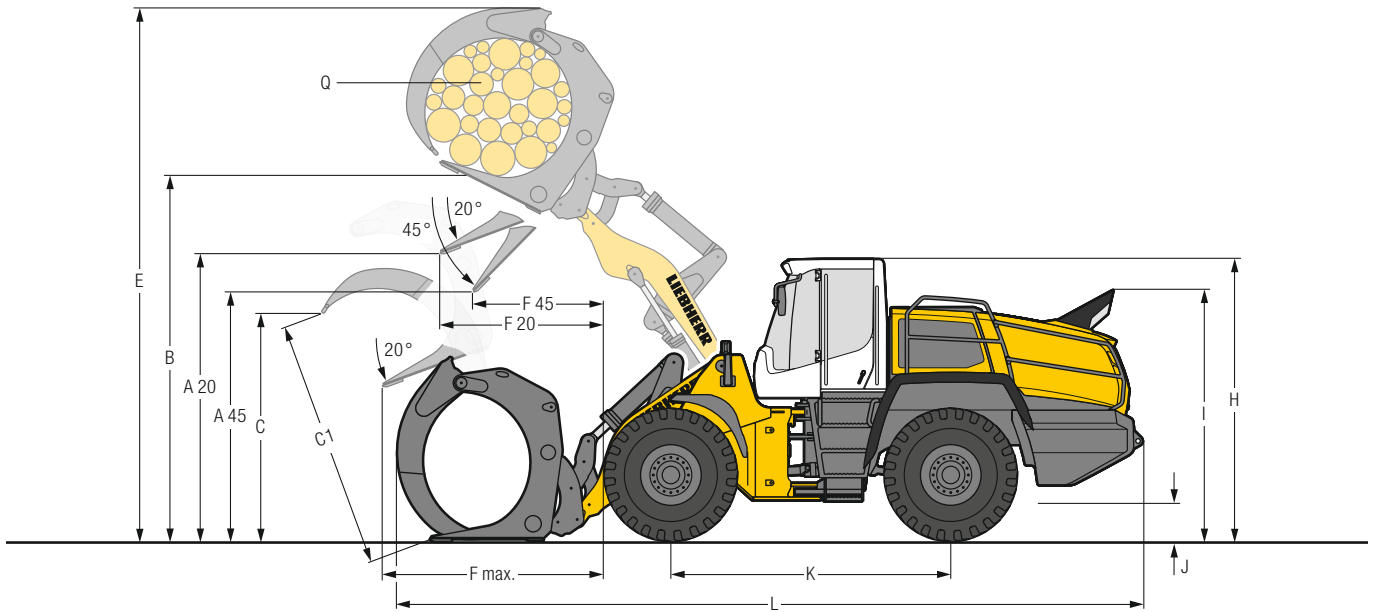

Log Grapple

			L 566	L 580
Geometry			IND-QC	IND-QC
A20	Discharge height at 20°	ft in	11'9"	11'7"
A45	Discharge height at 45°	ft in	9'7"	9'2"
B	Manipulation height	ft in	16'10"	16'10"
C	Max. grapple opening in loading position	ft in	8'8"	9'7"
C1	Max. grapple opening	ft in	10'	10'11"
E	Max. height	ft in	24'3"	24'7"
F20	Reach at max. lifting height at 20° discharge	ft in	7'1"	7'3"
F45	Reach at max. lifting height at 45° discharge	ft in	5'4"	5'4"
F max.	Max. reach	ft in	10'2"	10'4"
H	Height above operator's cab	ft in	11'10"	11'10"
I	Height above exhaust	ft in	10'7"	10'7"
J	Ground clearance	ft in	1'10"	1'7"
K	Wheelbase	ft in	11'11"	12'2"
L	Overall length	ft in	32'2"	33'
	Width over tires	ft in	9'9"	9'9"
Q	Grapple diameter	yd ²	3.70	4.20
	Grapple width	ft in	5'11"	5'11"
	Payload*	lb	18,080	20,280
	Operating weight*	lb	59,415	65,805
	Tire size		26.5R25 L4	26.5R25 L4

* The figures shown include the above tires, all lubricants, a full fuel tank, the ROPS/FOPS cab and the operator. Different tires and optional equipment will change the operating weight and payload.

IND-QC = Industrial lift arm with parallel guidance incl. quick coupler

Bucket Selection

L 566 – L 586

L 566

Lift arm	Bucket	Material density (lb/yd ³)									
		674	1,011	1,348	1,686	2,023	2,360	2,697	3,034	3,371	
ZK	GPB ₁ 5.5 yd ³							6.0			5.5
	6.1 yd ³						6.8			6.1	
ZK-HL	GPB ₁ 4.8 yd ³							5.4			4.8
	5.5 yd ³						6.0			5.5	
IND-QH	GPB ₁ 4.6 yd ³							5.1			4.6
	5.2 yd ³						5.8			5.2	
	LMB 8.5 yd ³			9.4						8.5	
	15.7 yd ³	15.7									
	HDB 7.8 yd ³				8.6						7.8
	14.4 yd ³	14.4									

L 586

Lift arm	Bucket	Material density (lb/yd ³)									
		674	1,011	1,348	1,686	2,023	2,360	2,697	3,034	3,371	
ZK	GPB ₂ 7.8 yd ³							8.6			7.8
	8.5 yd ³						9.4			8.5	
	RB 7.2 yd ³									7.2	6.8
	LMB 11.1 yd ³				12.3						11.1
HDB 11.1 yd ³				12.3						11.1	
ZK-HL	GPB ₂ 7.2 yd ³							8.0			7.2
	7.8 yd ³						8.6			7.8	
	RB 6.5 yd ³									6.5	6.2

L 580

Lift arm	Bucket	Material density (lb/yd ³)									
		674	1,011	1,348	1,686	2,023	2,360	2,697	3,034	3,371	
ZK	GPB ₁ 6.8 yd ³									7.5	6.8
	7.5 yd ³								8.2		7.5
	7.5 yd ³ *								8.2		7.5
ZK-HL	GPB ₁ 6.1 yd ³									6.8	6.1
	6.8 yd ³								7.5		6.8
	GPB ₂ 6.8 yd ³ *								7.5		6.8
IND-QC	GPB ₁ 5.9 yd ³									6.5	5.9
	6.5 yd ³								7.2		6.5
	LMB 9.8 yd ³				10.9						9.8
	18.3 yd ³	18.3									
	HDB 9.2 yd ³				10.1						9.2
	17.0 yd ³	17.0									

* Toothed buckets, hydraulic quick coupler and additional hydraulic circuits are not approved for rehandling application.

Bucket Filling Factor

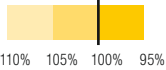

Lift Arm

ZK	Z-bar linkage, standard lift arm length
ZK-HL	Z-bar linkage, High Lift
IND-QC	Industrial lift arm with quick coupler, standard lift arm length

Bucket

GPB₁	General purpose bucket (Excavation bucket)
GPB₂	General purpose bucket (Rehandling bucket)
RB	Rock bucket
LMB	Light material bucket
HDB	High-dump bucket

Bulk Material Densities and Bucket Filling Factors

		lb/yd ³	%			lb/yd ³	%
Gravel	moist	3,203	105	Earth	dry	2,191	115
	dry	2,697	105		wet excavated	2,697	110
	crushed stone	2,528	100	Topsoil		1,854	110
Sand	dry	2,528	105	Basalt		3,287	100
	wet	3,203	110	Granite		3,034	95
Gravel and Sand	dry	2,865	105	Sandstone		2,697	100
	wet	3,371	100	Slate		2,950	100
Sand / Clay		2,697	110	Bauxite		2,360	100
Clay	natural	2,697	110	Limestone		2,697	100
	dry	2,360	110	Gypsum	broken	3,034	100
Clay / Gravel	dry	2,360	110	Coke		843	110
	wet	2,697	100	Slag	broken	3,034	100
Glass waste	broken	2,360	100	Compost	dry	1,348	105
	solid	1,686	100		wet	1,686	110
Wood chips / Saw dust		843	110	Paper	shredded / loose	1,011	110
Coal	heavy material density	2,023	110		recovered paper / cardboard	1,686	110
Waste	domestic waste	843	100		light material density	1,517	110
	bulky waste	1,686	100				

Tipping Load



What is tipping load?

Load at center of gravity of working equipment, so that the wheel loader just begins to tip over the front axle. This is the most unfavourable static-load position for the wheel loader. Lifting arms horizontal, wheel loader fully articulated at center pivot.

Pay load.

The pay load must not exceed 50% of the tipping load when articulated. This is equivalent to a static stability-margin factor of 2.0.

Bucket capacity.

The bucket volume is determined from the pay load.

$$\text{Pay load} = \frac{\text{Tipping load, articulated}}{2}$$

$$\text{Bucket capacity} = \frac{\text{Pay load (lb)}}{\text{Specific bulk weight of material (lb/yd}^3\text{)}}$$

Tires



Tire Types

	Size and tread code		Change of operating weight lb	Width over tires ft in	Change in vertical dimensions* ft in	Use
L 566 XPower®						
Bridgestone	26.5R25 VJT L3		353	9'9"	0.55"	Bulk material (firm ground conditions)
Bridgestone	26.5R25 VLTS L4		926	9'9"	1.73"	Gravel, Industry (firm ground conditions)
Bridgestone	26.5R25 VSDT L5		2,288	9'9"	1.97"	Stone, Mining spoil (firm ground conditions)
Bridgestone	26.5R25 VSDL L5		2,844	9'9"	2.24"	Stone, Scrap, Recycling (firm ground conditions)
Bridgestone	26.5R25 VSMS L5		3,525	9'9"	2.76"	Scrap, Recycling, Slag (firm ground conditions)
Bridgestone	26.5R25 VSNT L4		1,270	9'9"	1.85"	Gravel, Industry, Wood (firm ground conditions)
Bridgestone	750/65R25 VTS L3		434	10'1"	- 1.54"	Gravel, Industry, Wood (all ground conditions)
Continental	26.5R25 EM-Master L3		220	9'9"	1.61"	Bulk material (firm ground conditions)
Continental	26.5R25 EM-Master L4		1,164	9'7"	1.89"	Gravel, Industry, Wood (firm ground conditions)
Goodyear	26.5R25 RT-3B L3		714	9'9"	1.02"	Gravel (all ground conditions)
Goodyear	26.5R25 TL-3A+ L3		767	9'9"	1.18"	Sand, Gravel, Earthworks, Clay (all ground conditions)
Goodyear	26.5R25 GP-4D L4		961	9'9"	1.02"	Gravel, Industry, Wood (firm ground conditions)
Goodyear	26.5R25 RL-4K L4		1,711	9'10"	2.48"	Gravel, Industry, Stone (firm ground conditions)
Goodyear	26.5R25 RL-5K L5		2,743	9'10"	2.48"	Stone, Scrap, Recycling (firm ground conditions)
Goodyear	26.5R25 RL-5S L5		3,219	9'10"	2.48"	Scrap, Recycling, Slag (firm ground conditions)
Goodyear	26.5R25 RT-5D L5		2,222	9'10"	2.48"	Stone, Mining spoil (firm ground conditions)
Goodyear	750/65R25 TL-3A+ L3		335	10'2"	- 1.02"	Sand, Gravel, Industry, Wood (all ground conditions)
Michelin	26.5R25 XHA2 L3		0	9'9"	0"	Sand, Gravel (all ground conditions)
Michelin	26.5R25 X MINE PRO L5		2,619	9'11"	2.28"	Stone, Scrap, Recycling (firm ground conditions)
Michelin	26.5R25 XLD D2A L5		1,534	9'9"	1.50"	Stone, Mining spoil (firm ground conditions)
Michelin	26.5R25 XTXL L4		1,076	9'9"	0.91"	Gravel, Industry, Wood (firm ground conditions)
Michelin	750/65R25 XLD 65 L3T		- 9	10'	- 2.24"	Gravel, Industry, Wood (all ground conditions)
L 580 XPower®						
Bridgestone	26.5R25 VJT L3		353	9'9"	0.55"	Bulk material (firm ground conditions)
Bridgestone	26.5R25 VLTS L4		926	9'9"	1.73"	Gravel, Industry (firm ground conditions)
Bridgestone	26.5R25 VSDT L5		2,288	9'9"	1.97"	Stone, Mining spoil (firm ground conditions)
Bridgestone	26.5R25 VSDL L5		2,844	9'9"	2.24"	Stone, Scrap, Recycling (firm ground conditions)
Bridgestone	26.5R25 VSMS L5		3,525	9'9"	2.76"	Scrap, Recycling, Slag (firm ground conditions)
Bridgestone	26.5R25 VSNT L4		1,270	9'9"	1.85"	Gravel, Industry, Wood (firm ground conditions)
Bridgestone	750/65R25 VTS L3		392	10'1"	- 1.54"	Gravel, Industry, Wood (all ground conditions)
Continental	26.5R25 EM-Master L3		220	9'9"	1.61"	Bulk material (firm ground conditions)
Continental	26.5R25 EM-Master L4		1,164	9'9"	1.89"	Gravel, Industry, Wood (firm ground conditions)
Goodyear	26.5R25 RT-3B L3		714	9'9"	1.02"	Gravel (all ground conditions)
Goodyear	26.5R25 TL-3A+ L3		767	9'9"	1.18"	Sand, Gravel, Earthworks, Clay (all ground conditions)
Goodyear	26.5R25 GP-4D L4		961	9'9"	1.02"	Gravel, Industry, Wood (firm ground conditions)
Goodyear	26.5R25 RL-4K L4		1,711	9'10"	2.48"	Gravel, Industry, Stone (firm ground conditions)
Goodyear	26.5R25 RL-5K L5		2,743	9'10"	2.48"	Stone, Scrap, Recycling (firm ground conditions)
Goodyear	26.5R25 RL-5S L5		3,219	9'10"	2.48"	Scrap, Recycling, Slag (firm ground conditions)
Goodyear	26.5R25 RT-5D L5		2,222	9'10"	2.48"	Stone, Mining spoil (firm ground conditions)
Goodyear	750/65R25 TL-3A+ L3		291	10'2"	- 1.02"	Sand, Gravel, Industry, Wood (all ground conditions)
Michelin	26.5R25 XHA2 L3		0	9'9"	0"	Sand, Gravel (all ground conditions)
Michelin	26.5R25 X MINE PRO L5		2,619	9'11"	2.28"	Stone, Scrap, Recycling (firm ground conditions)
Michelin	26.5R25 XLD D2A L5		1,534	9'9"	1.50"	Stone, Mining spoil (firm ground conditions)
Michelin	26.5R25 XTXL L4		1,076	9'9"	0.91"	Gravel, Industry, Wood (firm ground conditions)
Michelin	750/65R25 XLD 65 L3T		- 53	10'	- 2.24"	Gravel, Industry, Wood (all ground conditions)
L 586 XPower®						
Bridgestone	29.5R25 VJT L3		322	10'8"	0.59"	Bulk material (firm ground conditions)
Bridgestone	29.5R25 VLTS L4		895	10'9"	1.57"	Gravel, Stone (firm ground conditions)
Bridgestone	29.5R25 VSDT L5		3,020	10'9"	1.97"	Stone, Mining spoil (firm ground conditions)
Bridgestone	29.5R25 VSDL L5		3,814	10'9"	2.36"	Stone, Scrap, Recycling (firm ground conditions)
Bridgestone	29.5R25 VSNT L4		1,570	10'9"	1.97"	Gravel, Industry, Wood (firm ground conditions)
Continental	29.5R25 EM-Master L3		317	10'8"	0.79"	Bulk material (firm ground conditions)
Continental	29.5R25 EM-Master L4		1,111	10'9"	1.57"	Gravel, Industry, Wood (firm ground conditions)
Goodyear	29.5R25 TL-3A+ L3		1,173	10'10"	1.42"	Sand, Gravel, Earthworks, Clay (all ground conditions)
Goodyear	29.5R25 GP-4D L4		1,111	10'8"	0.94"	Gravel, Industry, Wood (firm ground conditions)
Goodyear	29.5R25 RL-4K L4		2,478	10'9"	1.73"	Gravel, Industry, Stone (firm ground conditions)
Goodyear	29.5R25 RL-5K L5		3,527	10'10"	2.60"	Stone, Scrap, Recycling (firm ground conditions)
Goodyear	29.5R25 RT-5D L5		3,325	10'10"	2.20"	Stone, Mining spoil (firm ground conditions)
Goodyear	29.5R25 RL-5S L5		4,630	10'9"	2.60"	Scrap, Recycling, Slag (firm ground conditions)
Michelin	29.5R25 XHA2 L3		0	10'8"	0"	Sand, Gravel (all ground conditions)
Michelin	29.5R25 XLD D2A L5		2,064	10'8"	1.02"	Stone, Mining spoil (firm ground conditions)
Michelin	29.5R25 XTXL L4		1,336	10'9"	1.02"	Gravel, Industry, Wood (firm ground conditions)
Michelin	29.5R25 X MINE PRO L5		3,113	10'10"	1.65"	Stone, Scrap, Recycling (firm ground conditions)

* The stated values are theoretical and may deviate in practice.

Before operating the vehicle with tire foam filling or tire protection chains, please discuss this with the Liebherr-Werk Bischofshofen GmbH.

The Liebherr Wheel Loaders

Wheel Loader



		L 526	L 538	L 546	L 550 XPower®
Tipping load	lb	17,635	20,945	23,150	27,560
Bucket capacity	yd³	2.7	3.4	3.7	4.5
Operating weight	lb	25,950	29,760	31,305	40,895
Engine output	kW/HP	100/134	123/165	138/185	163/219

Wheel Loader



		L 556 XPower®	L 566 XPower®	L 580 XPower®	L 586 XPower®
Tipping load	lb	30,315	35,055	42,330	47,620
Bucket capacity	yd³	4.8	5.5	6.8	7.8
Operating weight	lb	43,210	52,690	60,955	71,870
Engine output	kW/HP	183/245	203/272	233/312	263/353

01.21

Environmental Protection Can Help You Earn Money!

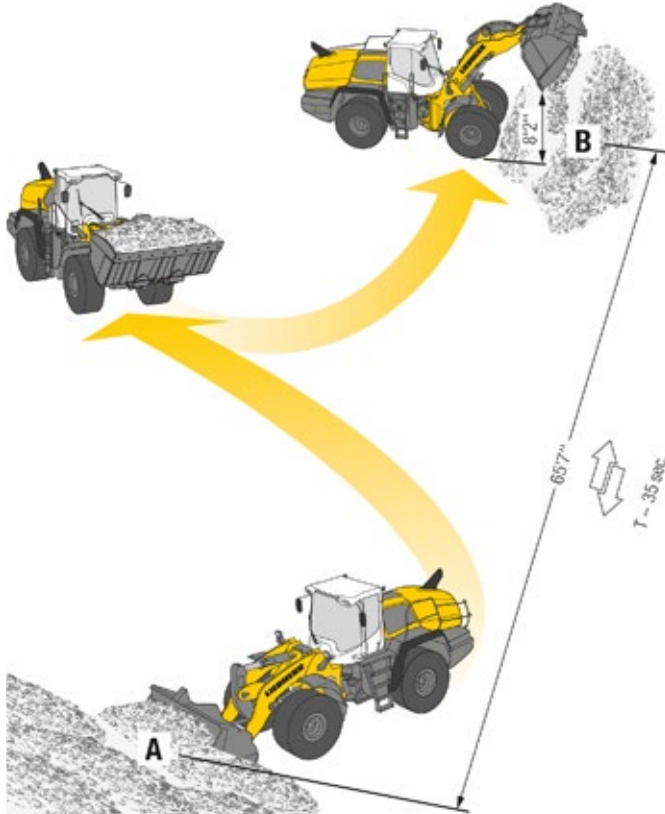

The Liebherr Standard Consumption Test – easy to reproduce and practical.

The Liebherr Standard Consumption Test determines the number of loading cycles that can be carried out with 1.3 gal of diesel. The material is taken from pile A and carried over a distance of 65'7" to point B. The time needed for each working cycle should be 35 seconds. Discharge at point B should take place from a height of 8'2". The working cycles continue until the 1.3 gal of diesel in the external measuring tank have been used up. The loader's fuel consumption per operating hour is calculated as follows:

$$\frac{400}{\text{Number of loading cycles}} = \text{Consumption per hour}$$

Values for the Liebherr wheel loaders

	Numbers of working cycles	Gallons / 100 US tons	Gallons / hour	Ø Gallons / hour*
L 526: 2.7 yd³	n = 48	0.82	2.19	1.64
L 538: 3.4 yd³	n = 40	0.79	2.64	1.83
L 546: 3.7 yd³	n = 38	0.76	2.77	1.85
L 550: 4.5 yd³	n = 32	0.76	3.30	2.39
L 556: 4.8 yd³	n = 29	0.76	3.65	2.62
L 566: 5.5 yd³	n = 22	0.87	4.81	3.20
L 580: 6.8 yd³	n = 20	0.79	5.28	3.66
L 586: 7.8 yd³	n = 15	0.90	7.05	4.35

* Wheel loader in practical customer applications with individual machine configurations. Average data from LiDAT from 25.01.2021.



Experience just how much fuel you can save!
www.encyplus.liebherr.com

Equipment

 Basic Wheel Loader	L 550	L 556	L 566	L 580	L 586
Crash protection, rear	+	+	+	+	+
Automatic central lubrication system	+	+	+	+	•
Battery main switch (lockable)	•	•	•	•	•
Electronic tractive force regulation for difficult ground conditions	•	•	•	•	•
Travel light (with additional headlights) on front section halogen	+	+	+	+	+
Travel light (with additional headlights) on front section LED	+	+	+	+	+
Ride control	•	•	•	•	•
Parking brake	•	•	•	•	•
Fire extinguisher 13 lb	+	+	+	+	+
Particle protection for radiator	+	+	+	+	+
Speed limiter 12.4 mph as a factory preset	+	+	+	+	+
Speed limiter V _{MAX} adjustable key on the control unit	•	•	•	•	•
DEF tank	•	•	•	•	•
Turbocharger insulation	+	+	+	+	+
Pre-heat system for cold starting	•	•	•	•	•
Rear license panel light	+	+	+	+	+
Combined inching-braking system	•	•	•	•	•
Fuel pre-filter	•	•	•	•	•
Fuel pre-filter with pre-heating	+	+	+	+	+
Large-mesh radiator	+	+	+	+	-
Cooling water pre-heating 230 V	+	+	+	+	+
Multi-disc limited slip differentials in both axles	•	•	•	•	•
Liebherr biodegradable hydraulic oil	+	+	+	+	+
Liebherr-SCR technology	•	•	•	•	•
Reversible fan drive	•	•	•	•	•
Widening for mudguard	+	+	+	+	+
Ramming guard with guard	+	+	+	+	-
Headlights halogen (double design on engine hood)	•	•	•	•	•
Headlights LED (double design on engine hood)	+	+	+	+	+
Guard for headlights	+	+	+	+	+
Auxiliary heater (Additional heating with engine preheating)	+	+	+	+	+
Dust protection for alternator	+	+	+	+	+
Lockable doors and engine hood	•	•	•	•	•
Tunnel package	+	+	+	-	-
Chassis protection rear	+	+	+	+	+
Chassis protection front	+	+	+	+	+
Air pre-cleaner TOP AIR	+	+	+	+	+
Toolbox with toolkit	•	•	•	•	•
Liebherr weighing system with "Truck Payload Assist"	+	+	+	+	+
Towing hitch	•	•	•	•	•
Additional handrails left	•	•	•	•	•
Additional handrails right	•	•	•	•	•

 Equipment	L 550	L 556	L 566	L 580	L 586
Working hydraulics lockout	•	•	•	•	•
Automatic bucket return programmable	•	•	•	•	•
Stroke limit damping	+	+	+	+	+
Fork carrier and pallet forks	+	+	+	+	+
High-dump bucket	+	+	+	+	+
Log grapple	+	+	+	+	-
Automatic lift arm position and lowering programmable	•	•	•	•	•
High Lift arms	+	+	+	+	+
Industrial lift arm	+	+	+	+	-
Lift arm Z-bar linkage	•	•	•	•	•
Hydraulic quick coupler	+	+	+	+	+
Hydraulic quick coupler LIKUFIX (for industrial lift arm)	+	+	+	+	-
Adjustable tipping speed	•	•	•	•	•
Tilt cylinder protection	+	+	+	+	+
Loading buckets incl. a range of cutting tools	+	+	+	+	+
Light material bucket	+	+	+	+	+
Load holding valves	+	+	+	+	+
Float position	•	•	•	•	•
Visualization of the equipment position	•	•	•	•	•
1st electro-hydraulic, proportional additional function, adjustable delivery flow	+	+	+	+	+
1st additional electro-hydraulic function for continuous sweeper and snow blower operation	+	+	+	+	+
2nd electro-hydraulic, proportional additional function, adjustable delivery flow	+	+	+	+	-
2nd additional electro-hydraulic function for continuous sweeper and snow blower operation	+	+	+	+	-



Operator's Cab

	L 550	L 556	L 566	L 580	L 586
Adapter plate for additional fastening on the multi-function rail	+	+	+	+	+
Adaptive working lighting	+	+	+	+	+
Access assistance to facilitate cleaning windscreen	•	•	•	•	•
Exterior mirror, electrical adjustable, with heating	+	+	+	+	+
Exterior mirror, tiltable and adjustable	•	•	•	•	•
Operating hour meter (integrated in display unit)	•	•	•	•	•
Operating hour meter (mechanic)	+	+	+	+	+
Electronical theft protection with code	+	+	+	+	+
Electronical theft protection with key with/ without driver identification	+	+	+	+	+
Storage box left	•	•	•	•	•
Operator's cab without steering wheel/steering column (not available as street legal) – joystick steering only	+	+	+	+	+
Operator seat "Comfort" – air-suspension with seat heating	•	•	•	•	•
Operator seat "Premium" – active air-suspension with seat air-condition, seat heating and headrest	+	+	+	+	+
Particle filter F7	•	•	•	•	•
Fire extinguisher in cab 4 lb	•	•	•	•	•
Rear window heated electrically	•	•	•	•	•
Audible horn control integrated into Liebherr control lever	+	+	+	+	+
Interior mirror right	•	•	•	•	•
Interior mirror left and right	+	+	+	+	+
Integral tire pressure monitoring system	+	+	+	+	+
Joystick steering	+	+	+	+	+
Floor mat	•	•	•	•	•
Clothes hooks (2 pieces)	•	•	•	•	•
Air conditioning system	•	•	•	•	•
Automatic air conditioning system	+	+	+	+	+
Cool box	+	+	+	+	+
3 way continuously adjustable steering column (height-adjustable, tilting, folding)	•	•	•	•	•
Steering stabilisation	•	•	•	•	•
LiDAT total use 1 year (for free)	•	•	•	•	•
Liebherr control lever with mini-joystick for 1st and 2nd electro-hydraulic, proportional additional function moving with operator's seat	+	+	+	+	+
Liebherr control lever moving with operator's seat (incl. kick down, travel direction)	•	•	•	•	•
Liebherr multi-lever control system moving with operator's seat (incl. kick down, travel direction)	+	+	+	+	+
Liebherr key with remote control incl. Coming Home / Leaving Home function	+	+	+	+	+
Premiumdisplay (Touchscreen), with height adjustment and tilting function	•	•	•	•	•
Preparation for radio installation	•	•	•	•	•
Radio Liebherr "Comfort" (USB/AUX/BLUETOOTH/handsfree set)	+	+	+	+	+
Radio Liebherr "Standard" (USB/AUX)	+	+	+	+	+

• = Standard
+ = Option
- = not available



Operator's Cab

	L 550	L 556	L 566	L 580	L 586
Amber beacon swiveling/fixed	+	+	+	+	+
Soundproof ROPS/FOPS cab	•	•	•	•	•
Bucket return with button integrated into Liebherr control lever	+	+	+	+	+
Wipe and wash system	•	•	•	•	•
Windscreen wiper single-sweep function with button	+	+	+	+	+
Headlights rear, single design, halogen/LED	+	+	+	+	+
Headlights rear, double design, LED	+	+	+	+	+
Headlights rear, sixfold, LED	+	+	+	+	+
Headlights front, double design, halogen	•	•	•	•	•
Headlights front, double design, LED	+	+	+	+	+
Sliding window left/right	•	•	•	•	•
Slipcover for operator seat	+	+	+	+	+
Windscreen guard	+	+	+	+	+
Sunblind rear	+	+	+	+	+
Sunblind front	•	•	•	•	•
Power socket 12 V	•	•	•	•	•
Power socket USB	•	•	•	•	•
First aid kit	+	+	+	+	+
Preparation for protective ventilation and dust filtrating device	+	+	+	+	+
Wide angle mirror	+	+	+	+	+
Cigarette lighter	•	•	•	•	•
2-in-1 steering – changeable	+	+	+	+	-



Safety

	L 550	L 556	L 566	L 580	L 586
Active personnel detection at the rear	+	+	+	+	+
Roof camera for front area monitoring (with Liebherr camera via Liebherr display)	+	+	+	+	+
Country-specific versions	+	+	+	+	+
Emergency steering system	•	•	•	•	•
Reversing obstruction detector	+	+	+	+	+
Back-up alarm audible	•	•	•	•	•
Back-up alarm visual	+	+	+	+	+
Rear space monitoring with camera (with Liebherr camera via Liebherr display)	•	•	•	•	•
Skyview 360°	+	+	+	+	+

Further information can be found
in the brochure "Assistance
systems for wheel loaders"
or you can find here:



Here you can download our
wheel loader brochures:



The Liebherr Group of Companies



Diverse Product Range

The Liebherr Group is one of the largest construction equipment manufacturers in the world. Liebherr's quality products and services hold a high reputation in many industries. The wide range includes domestic appliances, aerospace and transportation systems, machine tools and maritime cranes.

Exceptional Customer Benefit

Every product line provides a complete range of models in many different versions. With both their technical excellence and superior quality, Liebherr products offer customers the highest benefits in practical applications.

State-of-the-art Technology

Liebherr attributes great importance to the product areas of core technology and components, in order to achieve its consistent, top-quality products. Important modules and components are developed and manufactured in-house, for instance, the entire drive and control technology for the construction equipment and mining trucks.

Worldwide and Family-Owned

Hans Liebherr founded the Liebherr family company in 1949. Since that time, the enterprise has steadily grown to a group of more than 130 companies with more than 48,000 employees located on all continents. The corporate headquarters of the Group is Liebherr-International AG in Bulle, Switzerland. The Liebherr family is the sole owner of the company.

www.liebherr.us

⚠ WARNING

This product can expose you to chemicals including lead and lead compounds, which are known to the State of California to cause cancer and birth defects or other reproductive harm.
For more information go to www.P65warnings.ca.gov.

⚠ WARNING

Breathing diesel engine exhaust exposes you to chemicals known to the State of California to cause cancer and birth defects or other reproductive harm.

- ▶ Always start and operate the engine in a well-ventilated area.
- ▶ If in an enclosed area, vent the exhaust to the outside.
- ▶ Do not modify or tamper with exhaust system.
- ▶ Do not idle the engine except as necessary.

For more information go to www.P65warnings.ca.gov/diesel.