



DX520LC

Engine Power : DIN 6271, net 245kw (333ps) @1,800rpm

SAE J1349, net 245kw (328HP)@1,800rpm

Operating Weight : 50,700kg (111,800 lb)

Bucket Capacity(PCSA) : 0.92~3.2m³ (1.20~4.19cu.yd)

Width for 3.2m³ (PCSA) with cutter : 2,101mm(6'11")

without cutter : 2,024mm(6'8")



Technical Data

Engine

Model	Doosan DV11
Type	Water-Cooled, Common Rail, Direct Injection
Aspiration	Turbocharged Air to Air intercooled
No. of cylinders	6
Rated flywheel horse power	
DIN6271,net	245KW(333PS)at 1,800rpm
SAEJ1349,net	245KW(328HP)at 1,800rpm
Piston Displacement	10,964cc(669cu.in)
Maximum torque @ 1,300rpm	157kgf.m(1,540Nm, 1,137lbf.ft)
Bore and stroke	128mm X 142mm (5.0" X 5.6")
Starting system	24V x 7.0kw Electric motor
Batteries	2 X 12V X 150AH

Hydraulic System

e-EPOS (Electronic Power Optimizing System) allows the operator to maximize work efficiency over a full range of operating conditions and to minimize fuel consumption.

- Hydraulic system assures fully independent and combined operations.
- Automatic 2 speed travel system for high traction force and travel speed.
- Cross-sensing and fuel saving pump system.
- Auto idle system.
- 2-Working / 2-Power mode selection system.
- Computer aided engine-pump control.

Main pumps	Parallel, Bent-axis, axial piston
Max.oil flow	2 X 355 ℓ /min (2 X 93 US gpm, 2 X 78 Imp gpm)
Pilot pump	Gear pump
Max. oil flow	22 ℓ /min (5.8US gpm, 4.8Imp gpm)
Swing motor	
Relief valve	225bar (3,700psi, 260kgf/cm ²)
Main relief valves	
Boom/Arm/Bucket	Normal: 314bar (4,550psi, 320kgf/cm ²) Power Boost: 343bar(4,970psi, 350kgf/cm ²)
Travel circuit	314bar(4,550psi, 320kgf/cm ²)

Hydraulic cylinders

High-strength piston rods and tubes are used. Cylinder cushion mechanism is provided for all cylinders to assure shock-free operation and extend life of cylinder.

Cylinders	Q'ty	Bore X Rod dia. X Stroke
Boom	2	170 X 115 X 1,610mm(6.7" X 4.5" X 63")
Arm	1	190 X 130 X 1,805mm(7.5" X 5.1" X 71")
Bucket	1	170 X 115 X 1,341mm(6.7" X 4.5" X 52.8")

Super-structure revolving frame

A deep, full-reinforced box section. Heavy-gauge steel plates used for ruggedness.

Operator's cab

A roomy, independent, shock and noise-free operator's cab, 4 side safety glass windows give all-round visibility. Front window slides up and stores in the roof and side window can be opened for ventilation. Fully adjustable suspension seat. Air conditioner. ISO standard dab.

Noise Levels (dynamic value)

LWA External noise	
Guaranteed Sound Power Level	106 dB(A)(2000/14/EC)
Measured Sound Power Level	105 dB(A)(2000/14/EC)
LPA Operator noise	
	72 dB(A)(ISO 6396)

Controls. 2 Implement levers

Pilot pressure control type. Right lever is boom and bucket control, left lever for swing and arm control.

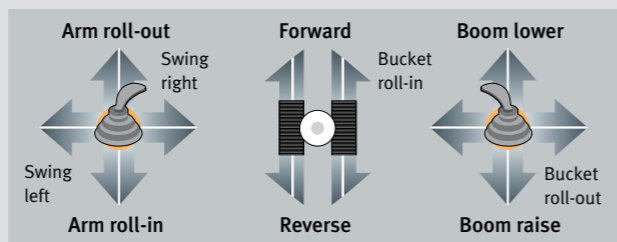

2 Travel pedals with levers

Pilot pressure control type. Independent drive at each track allows counter-rotation of the tracks. Levers are detachable.

Brake

Two oil disk brake on final drive input shafts. Parking brake is spring-set, hydraulic-released disc type.

Swing mechanism

High-torque, axial piston motor with planetary reduction gear bathed in oil. Swing circle is singlerow, shear type ball bearing with induction-hardened internal gear. Internal gear and pinion gear immersed in lubricant.

Swing speed	0 to 8.8 rpm(min ⁻¹)
Rear swing radius	3,700 mm(12'2")

Drive

Each track is driven by an independent, high-torque, axial piston motor through planetary reduction gear. Two levers or foot pedal control provide smooth travel or counter-rotation upon demand.

Travel speed (High/Low)	5.0/3.1km/h(3.1/1.9mph)
Maximum traction force	33,600 kgf(74,080 lbf)
Gradeability	35° (70%) continuous

Undercarriage

Tractor type undercarriage. Heavy-duty track frame, all welded stress-relieved structure. Top grade materials are used for toughness. Side frames are welded, securely and rigidly, to the track frame. Lifetime-lubricated track rollers, idlers and sprockets with floating seals. Track shoes of induction-hardened rolled alloy with triple grousers. Specially heat-treated connecting pins. Hydraulic track adjusters with shock-absorbing recoil springs.

Buckets

Capacity	CECE heaped	Width		Weight	Recommendation			
		Without side cutters	With side cutters		6.3m (20'8") Boom			
					2.4(7'10")Arm	2.9(9'6")Arm-Std.	9.0m (29'6") Boom 6.0(19'8")Arm	11.0m (20'8") Boom 8.0(26'3")Arm
0.92m ³ (1.20yd ³)	0.81m ³	1,236mm (49")	1,172mm (46")	707kg (1,560 lb)	-	-	-	A
1.27m ³ (1.66yd ³)	1.10m ³	1,445mm (57")	1,376mm (54")	1,091kg (2,410 lb)	-	-	A	-
3.20m ³ Std.(4.19yd ³)	2.87m ³	2,101mm (83")	2,024mm (80")	2,600kg (5,730 lb)	A	B	-	-
HD. 1.73m ³ (2.26yd ³)	1.58m ³	1,301mm (51")	1,224mm (48")	1,831kg (4,040 lb)	A	A	-	-
HD. 2.01m ³ (2.63yd ³)	1.82m ³	1,451mm (57")	1,374mm (54")	1,948kg (4,290 lb)	A	A	-	-
HD. 2.29m ³ (3.00yd ³)	2.07m ³	1,601mm (63")	1,524mm (59")	2,106kg (4,640 lb)	A	A	-	-
HD. 2.85m ³ (3.73yd ³)	2.55m ³	1,901mm (75")	1,824mm (72")	2,381kg (5,250 lb)	A	A	-	-

A. Suitable for materials with density of 2,000 kg/m³ (3,370 lb/CU • yd) or less
 B. Suitable for materials with density of 1,600 kg/m³ (2,700 lb/CU • yd) or less
 C. Suitable for materials with density of 1,100 kg/m³ (1,850 lb/CU • yd) or less

Number of rollers and shoes(each side) ground contact area

Upper rollers	2+1(Center)
(Standard shoe)	
Lower rollers	9
Track shoes	53
Overall track length	5,465mm(17'11")

Weight

Equipped with 6.3m(20'8")boom, 2.9m(9'6")arm, and 3.2m³(4.19yd³; PCSA heaped) bucket and 600mm(24")TG shoes.

Shoe type	shoe width	Operating weight	Ground pressure
Triple grouser	600mm(24") (Std.)	50,700kg (111,800lb)	0.88kgf/cm ² (86kpa, 12.5psi)
	750mm(28") (Opt.)	51,400kg (113,300lb)	0.71kgf/cm ² (70kpa, 10.1psi)
	800mm(32") (Opt.)	51,700kg (114,000lb)	0.67kgf/cm ² (66kpa, 9.5psi)
	900mm(34") (Opt.)	52,200kg (115,100lb)	0.60kgf/cm ² (59kpa, 8.5psi)
Double grouser	600mm(24") (Opt.)	51,600kg (113,800lb)	0.89kgf/cm ² (87kpa,12.6psi)

Service refill capacities

	Liters	US gal	Imp gal
Fuel tank	620	164	136
Cooling system	40	10.6	8.8
Lubrication			
	Liters	US gal	Imp gal
Engine oil	44	11.6	9.7
Swing drive(each)	4	1.1	0.9
Final drive(each)	6	1.6	1.3
Hydraulic tank	500	87.2	110

Dimensions & Working Ranges

Lifting Capacities

Dimensions (6,300mm(20'8")Boom, 2,900mm(9'6")Arm, 600mm(24")shoe) - Std.

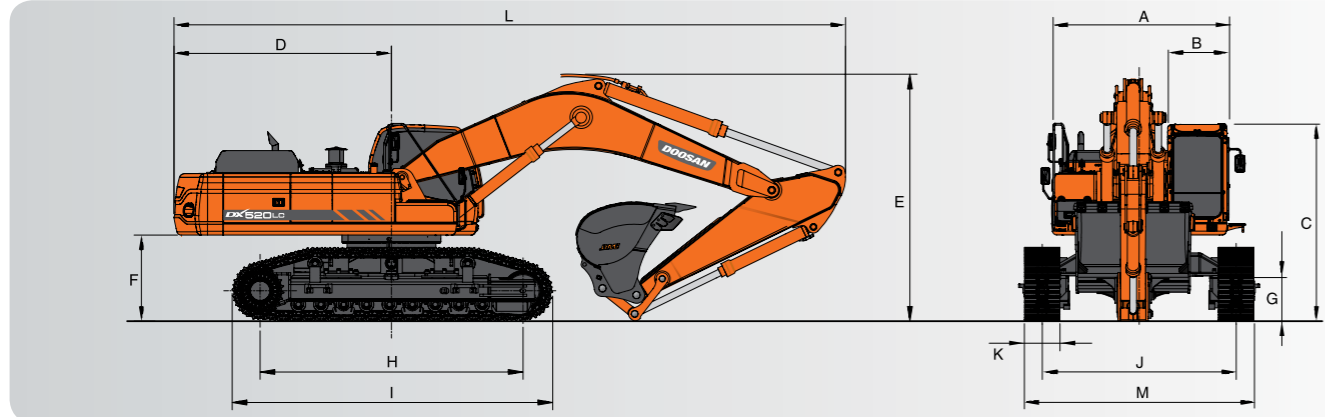

Boom length	9.0m(29'6")	(Std.) 6.3m(20'8")	11.0m(36'1")
Arm length	6.0m(19'8")	(Std.) 2.9m(9'6")	8.0m(26'3")
Bucket type(pcsa)	1.27m ³	(Std.) 3.2m ³	0.92m ³
A Overall width of upper structure	2,990mm(9'10")		
B Overall width of cab	1,010mm(3'4")		
C Overall height of cab	3,350mm(11'0")		
D Tail swing radius	3,700mm(12'2")		
E Overall height(Hose)	3,910mm(13'0")	4,200mm(13'9")	4,070mm(13'4")
F Clearance under counterweight	1,460mm(4'9")		
G Ground clearance	770mm(2'6")		
H Tumbler distance	4,470mm(14'8")		
I Track length	5,465mm(17'11")		
J Track gauge(Standard Track)	3,300/2,740mm(10'10"/9'10")		
J' Track gauge(Narrow Track)	2,920/2,360mm(9'7"/7'9")		
K Track shoe width	600mm(2')		
L Overall length	14,050mm(46'1")	11,430mm(37'6")	16,090mm(52'9")
M Overall track width(Standard Track)	3,900mm(12'10")		
M' Overall track width(Narrow Track)	3,520mm(11'7")		

Working ranges (Std.)

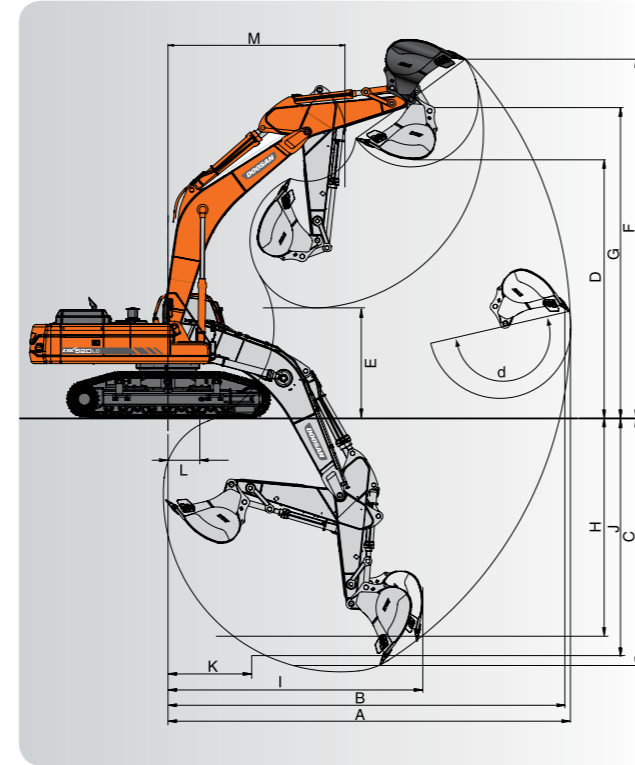

Digging forces(Maximum radialtooth forces)

	6.0m Arm	(Std.) 2.9m Arm	8.0m Arm
Bucket digging force	20,300 kgf	30,100 kgf	15,200 kgf
	200 kn	300 kn	150 kn
	44,800 lbf	66,400 lbf	33,500 lbf
Arm digging force	15,100 kgf	25,800 kgf	11,900 kgf
	150 kn	250 kn	120 kn
	33,300 lbf	56,900 lbf	26,200 lbf

*At power boost
*ISO

	9,000mm(29'6")	(Std.) 6,300mm(20'8")	11,000mm(36'1")
Boom length	9,000mm(29'6")	(Std.) 6,300mm(20'8")	11,000mm(36'1")
Arm length	6,000mm(19'8")	(Std.) 2,900mm(9'6")	8,000mm(26'3")
Bucket type(pcsa)	1.27m ³	(Std.) 3.2m ³	0.92m ³
A. Max. digging reach	16,060(52'8")	10,750(38'7")	19,610(64'4")
B. Max. digging reach at ground level	15,870(52'1")	10,460(34'4")	19,460(63'10")
C. Max. digging depth	11,800(38'9")	6,770(22'3")	15,130(49'8")
D. Max. dumping height	9,840(32'3")	6,720(22'1")	11,950(39'2")
E. Min. dumping height	2,080(6'10")	2,950(9'8")	1,980(6'6")
F. Max. digging height	12,800(41'12")	9,600(31'6")	14,520(47'8")
G. Max. bucket pin height	11,455(37'7")	8,520(27'4")	10,735(35'3")
H. Max. vertical wall depth	10,330(33'11")	1,190(3'11")	12,840(42'2")
I. Max. radius vertical	9,510(31'2")	10,100(33'2")	9,730(31'11")
J. Max. digging depth(8'level)	11,685(38'4")	6,590(21'7")	15,020(49'3")
k. Min. radius 8' line	4,910(16'1")	3,215(10'7")	4,930(16'2")
L. Min. digging reach	250(10")	1,240(4'1")	270(11")
M. Min. swing radius	6,470(21'3")	4,750(15'7")	6,210(20'4")
d. Bucket angle	175°	174°	178°

Standard

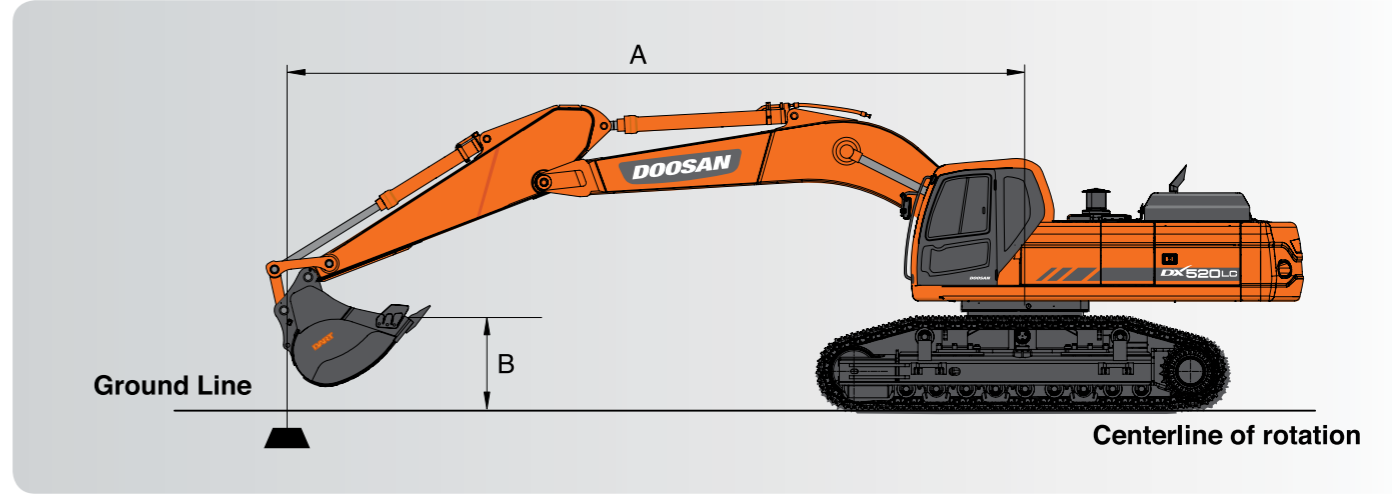

Metric Boom : 6,300mm(20'8") Arm : 2,900mm(9'6") Bucket : SAE 3.2m³ HEAPED(CECE 2.87m³) Shoe : 600mm(2')(TG) Unit : 1,000kg

A(m)	2		3		4		5		6		7		8		9		Max. Reach		A(m)		
B(m)	☺	☹	☺	☹	☺	☹	☺	☹	☺	☹	☺	☹	☺	☹	☺	☹	☺	☹	A(m)		
7																			*9.80	*9.80	7.63
6												*10.67	*10.67	*10.25	*10.25				*10.15	*10.15	8.16
5										*12.56	*12.56	*11.43	*11.43	*10.67	*10.67				*10.38	9.71	8.53
4					*21.12	*21.12	*16.61	*16.61	*14.01	*14.01	*12.35	*12.35	*11.23	10.68					*10.61	9.10	8.77
3					*25.16	*25.16	*18.97	*18.97	*15.50	*15.50	*13.32	13.02	*11.84	10.46					*10.89	8.74	8.90
2					*27.91	*27.91	*20.89	*20.89	*16.81	16.25	*14.20	12.70	*12.41	10.25					*11.21	8.59	8.90
1					*25.78	*25.78	*22.12	21.32	*17.75	15.88	*14.87	12.44	*12.83	10.07					*11.58	8.65	8.80
0 (Ground)			*15.87	*15.87	*27.86	*27.86	*22.60	21.02	*18.25	15.63	*15.23	12.26	*13.03	9.94					*11.99	8.93	8.57
-1	*16.29	*16.29	*21.11	*21.11	*28.24	*28.24	*22.39	20.89	*18.23	15.50	*15.21	12.16	*12.89	9.88					*12.44	9.50	8.21
-2	*21.47	*21.47	*26.94	*26.94	*26.72	*26.72	*21.51	20.91	*17.65	15.48	*14.70	12.15							*12.93	10.49	7.70
-3	*27.09	*27.09	*30.48	*30.48	*24.41	*24.41	*19.89	*19.89	*16.38	15.58	*13.46	12.24							*13.41	12.20	7.02
-4	*32.77	*32.77	*25.85	*25.85	*21.06	*21.06	*17.28	*17.28	*14.07	*14.07									*13.80	*13.80	6.09
-5			*19.36	*19.36	*16.09	*16.09													*13.74	*13.74	4.76

Feet Unit : 1,000lb

A(ft)	10'		15'		20'		25'		30'		Max. Reach		A(ft)	
B(ft)	☺	☹	☺	☹	☺	☹	☺	☹	☺	☹	☺	☹	A(ft)	
25'												*21.31	*21.31	23.67
20'												*22.29	*22.29	26.62
15'							*22.81	*22.81				*23.09	20.76	28.38
10'							*28.68	*28.68	*24.70	*24.70		*23.97	19.29	29.18
5'									*27.13	25.01		*25.09	18.94	29.09
0 (Ground)	*35.85	*35.85	*55.22	53.97	*39.49	33.59	*30.42	23.66				*26.44	19.69	28.11
-5'	*53.87	*53.87	*53.26	*53.26	*38.98	33.27	*29.73	23.48				*27.99	21.94	26.13
-10'	*66.03	*66.03	*47.54	*47.54	*35.26	33.51						*29.61	27.14	22.89
-15'	*48.98	*48.98	*36.40	*36.40								*30.59	*30.59	17.70

- RATINGS ARE BASED ON SAE J1097
- THE LOAD POINT IS A HOOK LOCATED ON THE BACK OF THE BUCKET.
- * RATED LOADS ARE BASED ON HYDRAULIC CAPACITY.
- RATED LOADS DO NOT EXCEED 87% OF HYD. CAPACITY OR 75% OF TIPPING CAPACITY.

☺ : Rating Over Front
☹ : Rating Over Side or 360 degree



Doosan Infracore Korea Office

27/F, Doosan Tower 18-12, Euljiro-6Ga, Jung-Gu
Seoul 100-730 Korea
Tel : 82 2 3398 8114

Doosan Infracore Europe S.A.

Add 1A, Rue Achille Degrace Frameries B7080 Belgium
Tel : 32 478295266

Doosan Infracore U.K.

Unit 6.3- Nantgarw Park Treforest Ind. Estate Cardiff
CF157QU U.K .
Tel : 44 1443 845650

Doosan Infracore Europe S.A. Germany

Heinrich von stephan Strasse 2 Langenfeld-Fuhrkamp
DE-40764 Germany
Tel : 49 2173 2035218

Doosan Infracore France

ZAC de la Clef Saint Pierre - Buroplus 2 1a,
avenue Jean d' Alambert Elancourt F78990 France
Tel : 33 1 3016 2151

Doosan Infracore America Corporation

2905 Shawnee Industrial Way, Suwanee, Georgia 30024, U. S. A
Tel : 770 831 2236

Doosan Infracore China Co., Ltd.

No.28 Wuzhishan Road, Eco&Tech. Development Area,
Yantai Shandong 264006 China
Tel : 135 0535 2797

Doosan Infracore Russia

123610, MOSCOW / Russia Fed., Kransnopresnenskaya quay 12,
Office No. 1503
Tel: 7 495 258 1837

Doosan Infracore Middle East Center (Dubai)

P.O.Box 183127, Al-Serkal Building, Air Port Road,Dubai, U.A.E
Tel : 971 4 295 2781~2

Doosan Infracore do Brasil Serviços de Suporte Comercial Ltda.

Alameda Santos 2222 CJ52, 5a andar, Cerqueria Cesar
CEP 01418.200 Sao Paulo Brazil
Tel : 55 11 3061 3227

Doosan Infracore India Pvt.Ltd

3rd Floor, TNPL Building No.67, Mount Road,
Guindy Chennai 600032 India
Tel : 91 99 4064 8687



ce.doosaninfracore.co.kr